

Rotech Gate **Automation**

PC 50

Reflective P E Beam



The **PC50 reflective beam** is a high quality compact unit made from ABS plastic and is waterproof to IP67.

The PE beam is supplied with a mounting bracket to allow easy adjustment. Alignment of the beam is achieved through adjustment of the potentiometer mounted on top of the PE beam.

The two LED's on top of the beam indicate the status as shown below.

The other switch allows the contacts to be changed from N/O to N/C without changing the connections. The maximum operating distance is 10 metres, input voltage is 12 – 240vdc or 24 – 240vac and the relay is rated at 3 amps.

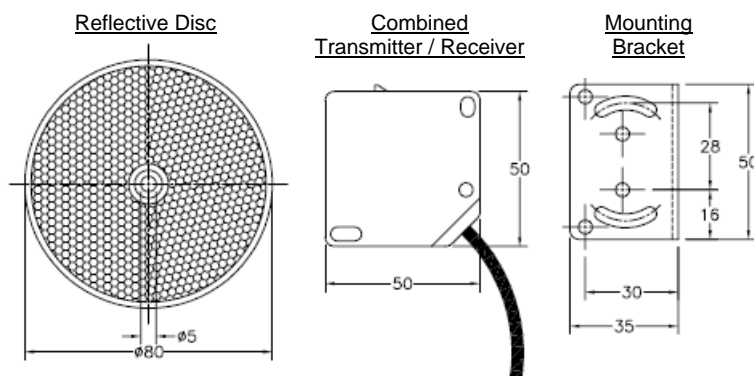

TECHNICAL INFORMATION

Power Supply	12-240v DC 24-240v AC
Power Consumption	100mA
Maximum Distance	10 Metre
Contact Rating	3A @ 240v
Protection	IP 65
Dimensions	50 x 50 x 20

Green LED	Yellow LED Target Present	Status
ON	OFF	Supply OK - Not aligned
OFF	OFF	Aligned but low power (No output)
OFF	ON	Dirt Alarm - Aligned but low power (Output OK)
ON	ON	Stable Function

P.O. Box 425, Albany Creek, QLD 4035, Australia

T: +61 (0)7 3205 1123

E: info@rotech.com.au

F: +61 (0)7 3205 1124

www.rotech.com.au