

# SENTINEL NV SERIES BOOM GATE



## SENTINEL NV SERIES BOOM GATE

**BOOM GATE MODELS**                      3.0 METRE  
    4.5 METRE  
    6.0 METRE

**CABINETS** 1.6 MM ZINC ANNEALED STEEL, ZINC PRIMED & UV STABLE POWDER COATED. AVAILABLE IN 1.6 MM STAINLESS STEEL, ETCH PRIMED AND UV STABLE POWDER COATED.

**COLOURS**  
 THE STANDARD COLOUR IS A WHITE CABINET WITH A RED COVER. OTHER COLOURS ARE AVAILABLE ON REQUEST. (NOTE: EXTENDED DELIVERY TIME AND ADDITIONAL COST MAY BE INCURRED FOR SOME OTHER COLOUR OPTIONS.)

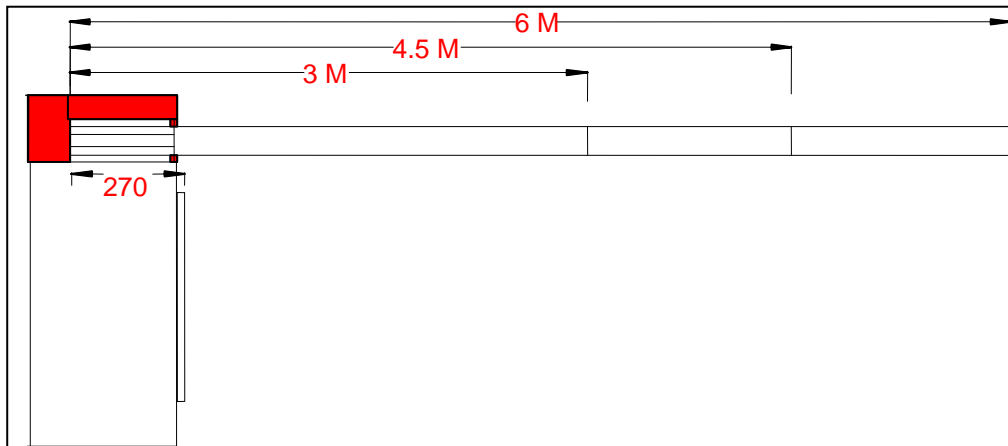

**MOTOR**  
 ALL NV SERIES ARE FITTED WITH A 240V / AC SINGLE PHASE, 80 WATT TORQUE MOTOR.  
 3 AND 4.5 METRE BOOM GATES ARE FITTED WITH A 10 RPM OUTPUT RATIO. (OPENING AND CLOSING TIMES BETWEEN 3 & 5 SECONDS.)  
 THE 6 METRE BOOM GATE IS FITTED WITH A 5.5 RPM OUTPUT RATIO. (OPENING AND CLOSING TIMES BETWEEN 5 & 7 SECONDS.)

**HANDING**

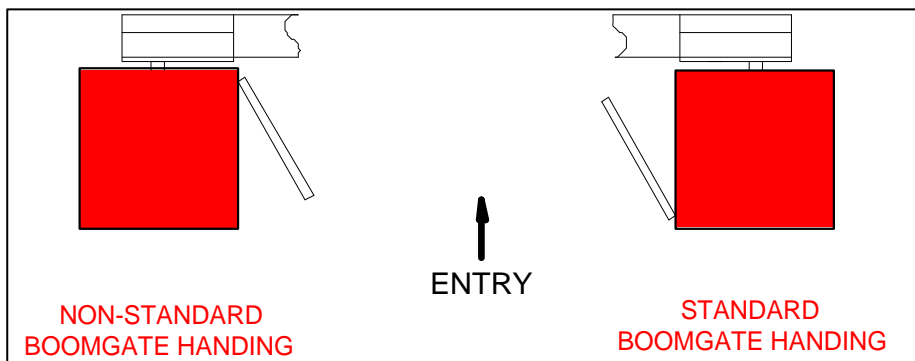

## **BOOM GATE OPTIONS**

<b><u>BL 100 B</u></b>	BUILT IN SAFETY LOOP.
<b><u>BL 110 B</u></b>	TIME DELAY ON CLOSING.
<b><u>LD 100</u></b>	240V/AC LOOP DETECTOR FOR ADDITIONAL SAFETY LOOPS, FREE EXIT LOOPS, ARMING LOOPS.
<b><u>LD 102</u></b>	12-26V/DC LOOP DETECTOR FOR ADDITIONAL SAFETY LOOPS, FREE EXIT LOOPS, ARMING LOOPS.
<b><u>RELAYS</u></b>	240V/AC OR 12V/DC POTENTIAL FREE CONTACTS FOR TICKET ISSUING.
<b><u>15 PE BEAMS</u></b>	PHOTO ELECTRIC BEAMS CAN BE USED AS AN ADDITIONAL SAFETY DEVICE OR REPLACE THE IN GROUND INDUCTION LOOPS.
<b><u>AUX POWER</u></b>	12V/DC 2A POWER SUPPLY FOR 15 PE SUPPLY BEAMS, RELAYS, LOOP DETECTORS AND KEY PADS.
<b><u>ARTICULATED ARM</u></b>	LOW CLEARANCE IN UNDERGROUND CAR PARKS.
<b><u>FOLDING SUPPORT POST</u></b>	GAS STRUT DAMPENED BOOM POLE SUPPORT.
<b><u>MAGNETIC LOCK</u></b>	100 KG'S HOLDING FORCE TO REDUCE THE RISK OF VANDALISM AND UNAUTHORISED ENTRY OR EXIT BY LIFTING OR BENDING.
<b><u>SUPPORT POST</u></b>	ADJUSTABLE SUPPORT POST REDUCES THE RISK OF VANDALISM THE POLE CAN BE SECURELY LOCKED SHUT WITH A PAD LOCK WHEN NOT IN USE.
<b><u>FOLDING FENCE</u></b>	3 METER & 4.5 METRE. THE FOLDING FENCE PREVENTS ACCESS BY PEDESTRIANS UNDER THE BOOM. THE FENCE RETRACTS AND FOLDS FLAT WITH THE POLE IN THE OPEN POSITION.

## INSTALLATION INSTRUCTIONS

UNPACK THE BOOM GATE BY LAYING THE CABINET ON ITS SIDE WITH THE ADDRESS LABEL FACING UP.

OPEN THE BOTTOM OF THE CARTON AND FOLD THE LOWER CARTON FLAP UNDER THE CARTON.

STAND THE CARTON UPRIGHT AND OPEN THE TOP OF THE CARTON.

REMOVE THE HOLD DOWN BARS FROM THE TOP OF THE CABINET.

LIFT THE CARTON OVER THE BOOM GATE CABINET.

OPEN THE CABINET DOOR AND REMOVE THE FOAM PACKING ON TOP OF THE CONTROL PANEL.

REMOVE ALL OTHER PACKING AND DISPOSE OF THOUGHTFULLY.

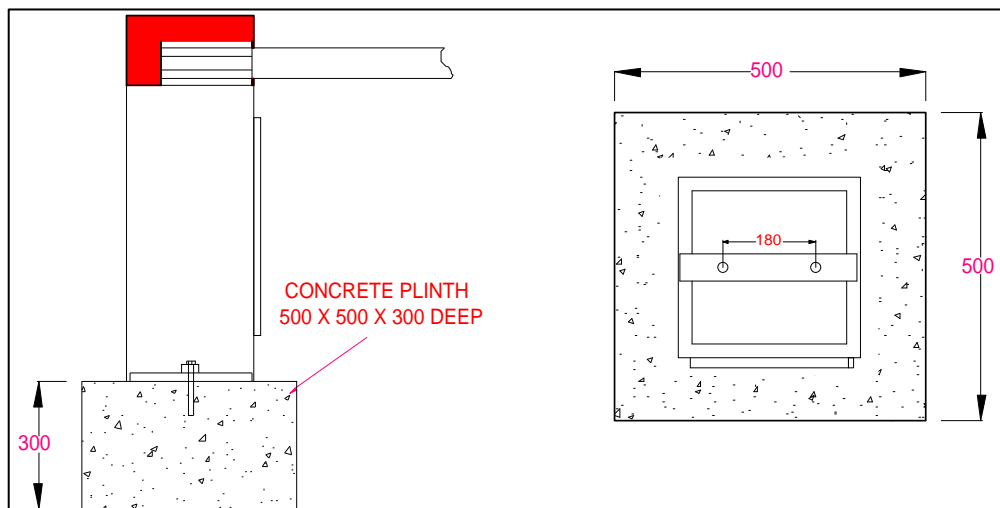

PLACE HOLD DOWN BARS IN THE BOTTOM OF THE CABINET, MARK AND DRILL FOR FIXINGS.

**(NOTE: 3 AND 4.5 METER BOOM GATE ARE SUPPLIED WITH 1 HOLD DOWN BAR. 6 METER BOOM GATES ARE SUPPLIED WITH 2 HOLD DOWN BARS.)**

HOLD DOWN BAR CAN BE FIXED BY EITHER DYNA BOLTS, CHEMICAL ANCHORS OR LOXINS, WITH A MINIMUM OF 100MM PENETRATION INTO THE CONCRETE SLAB.

LEVEL THE CABINET IN BOTH VERTICAL PLANES WITH A LEVEL, USING PACKING UNDER THE BASE OF THE CABINET.

## REQUIRED POWER SUPPLY

A DEDICATED 10 AMP 240V/AC POWER CIRCUIT WITH EARTH LEAKAGE PROTECTION SHOULD BE SUPPLIED BY AN **AUTHORISED ELECTRICAL CONTRACTOR**.

CHECK WITH YOUR LOCAL POWER SUPPLY AUTHORITY OR ELECTRICAL CONTRACTOR AS REQUIREMENTS MAY CHANGE FROM STATE TO STATE.

HAVE THE ELECTRICAL CONTRACTOR CONNECT THE POWER SUPPLY INTO THE DOUBLE GPO IN THE BOTTOM OF THE CABINET AND TEST.

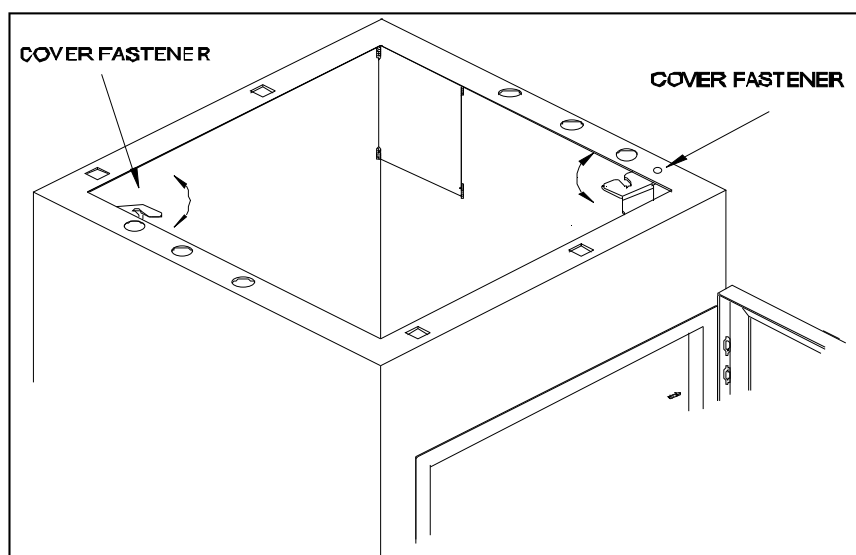

CONNECT ALL FIELD WIRING E.G. INDUCTION LOOPS, PE BEAMS AND TICKET ISSUING EQUIPMENT INTO THE CONTROL PANEL TERMINALS AS PER THE WIRING DIAGRAM FITTED TO THE INSIDE OF THE CABINET DOOR OR AS PER INDIVIDUAL WIRING INSTRUCTIONS.

SWITCH POWER ON AND USING THE TOGGLE SWITCH LOCATED ON THE FRONT OF THE CONTROL PANEL, RAISE THE BOOM ARM TO THE OPEN POSITION.

FIT THE BOOM POLE IN THE BOOM POLE CLAMP BY GENTLE SQUEEZING THE POLE OVAL AND PUSHING IT DOWN TILL IT IS FLUSH WITH THE OTHER END OF THE POLE CLAMP.

TIGHTEN THE EIGHT CLAMP BOLTS AND NYLON CAP NUTS. (NOTE: LIQUID SOAP ON THE POLE HELPS IT SLIDE EASILY IN THE POLE CLAMP.)

TOGGLE THE BOOM GATE TO THE CLOSE POSITION AND FIT THE BOOM POLE DECALS AS PER INSTRUCTIONS OVERLEAF.

## REFLECTIVE DECAL FIXING INSTRUCTIONS

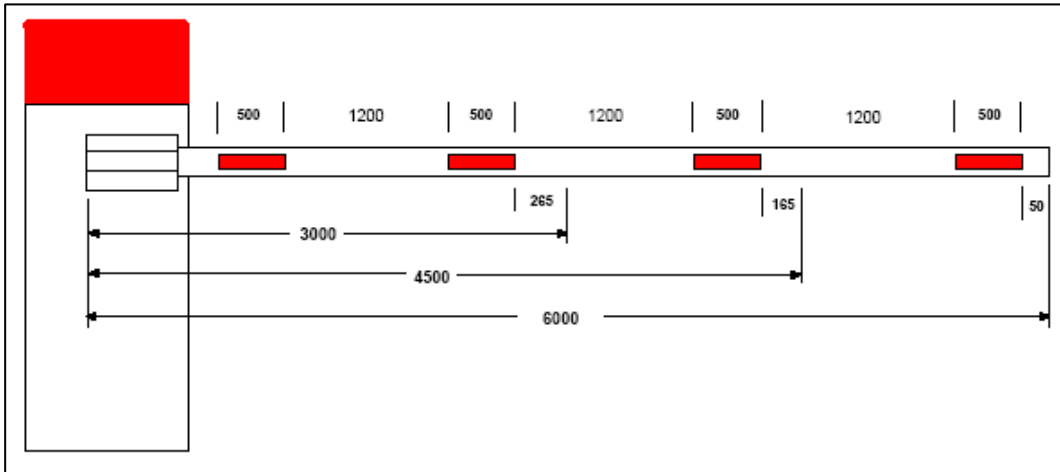

**NOTE:** APPLY 50mm MASKING TAPE TO THE RED SIDE OF THE REFLECTIVE STICKER TO STOP THE DECAL FROM STRETCHING. REMOVE THE PROTECTIVE BACKING, ALIGN AND FROM ONE EDGE PRESS FIRMLY REMOVING ANY AIR POCKETS, THEN REMOVE THE MASKING TAPE.

LEVEL BOOM POLE BY ADJUSTING THE ADJUSTABLE ARM ON THE MOTOR BASE AND TIGHTENING LOCK NUTS WHEN BOOM POLE IS LEVEL.

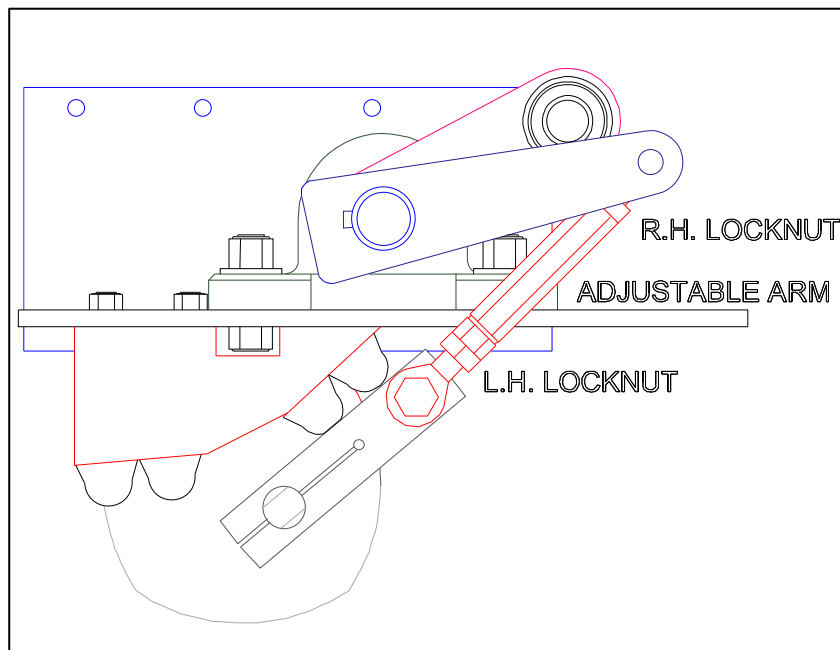

## LOOPS AND LOOP DETECTORS

1. THE LOOP AND FEEDER SHOULD BE MADE FROM 1.5MM SQ. INSULATED COPPER WIRE. THE LEADER SHOULD BE TWISTED TIGHTLY WITH AT LEAST 20 TURNS PER METRE. FEEDERS THAT MAY PICK UP ELECTRICAL NOISE SHOULD USE A SCREENED CABLE WITH THE EARTH SHIELD CONNECTED TO THE LOOP DETECTOR AT PIN 9.
2. THE LOOP SHOULD BE EITHER SQUARE OR RECTANGULAR WITH A MINIMUM DISTANCE OF 1 METRE BETWEEN OPPOSITE SIDES. LARGE LOOPS WITH A CIRCUMFERENCE GREATER THAN 10 METERS SHOULD USE 2 TURNS OF CABLE, WHILE SMALLER LOOPS WITH A CIRCUMFERENCE LESS THAN 6 METRES SHOULD USE 4 TURNS OF CABLE. WHEN TWO LOOPS ARE IN CLOSE PROXIMITY TO EACH OTHER IT IS RECOMMENDED TO USE 3 TURNS IN ONE LOOP AND 4 TURNS OF CABLE IN THE OTHER.
3. CROSS TALK IS A TERM USED TO DESCRIBE THE INTERFERENCE BETWEEN TWO ADJACENT LOOPS. TO AVOID THIS LOOPS SHOULD BE AT LEAST 1 METRE APART AND ON DIFFERENT FREQUENCY SETTINGS.
4. FOR LOOP INSTALLATION, SLOTS SHOULD BE CUT IN THE ROADWAY OR CONCRETE 4MM WIDE AND 30- 50 MM DEEP. CORNERS SHOULD BE CUT AT 45° TO PREVENT DAMAGE TO THE CABLE.
5. FOR BEST RESULTS THE LOOP AND FEEDER SHOULD NOT HAVE ANY JOINS. RUN THE CABLE FROM THE LOOP DETECTOR AROUND THE LOOP THE DESIRED AMOUNT OF TURNS THEN BACK TO THE LOOP DETECTOR, REMEMBER THAT WHEN YOU TWIST THE LEADER THAT THE CABLE WILL SHORTEN SO ALLOW ENOUGH CABLE TO RUN BACK TO THE LOOP DETECTOR.
6. AFTER THE LOOP CABLE HAS BEEN PLACED INTO THE SLOT, FILL THE SLOT WITH EPOXY COMPOUND OR BITUMEN FILLER.

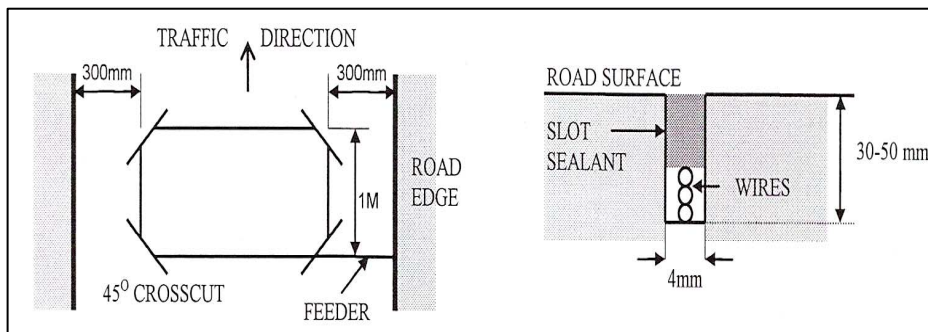

### LOOP DETECTOR TECHNICAL DATA

<b>OPERATING POWER</b>	LD 100	200-260 V/AC 50Hz (1.5 VA.)
	LD 102	11-26 V/AC-DC 50-60 Hz (95Ma. max.)
<b>MAX RELAY CAP.</b>	0.5 AMP – 220V/AC.	
<b>RESPONSE TIME.</b>	120m/sec.	
<b>FREQUENCY RANGE.</b>	15 -1500μH	
<b>DIMENSIONS</b>	80(H) X 40(W) X 79(D)	

## CONTROL LOGIC

### BMBA CONTROL PANEL.(BL100B TYPICAL)

- 1 240V/AC (50HZ) SUPPLY
- 2 NEUTRAL
- 3 EARTH
- 4 240V **RAISE** OUTPUT TO THE MOTOR
- 5 240V **LOWER** OUTPUT TO THE MOTOR
- 6 N/O PULSE TRIGGER (CARD READER ETC.) THIS RAISES THE BOOM GATE UNTIL THE VEHICLE CLEARS THE SAFETY LOOP OR PE BEAM AND THEN CLOSES. IF THE LOOP OR PE BEAM ARE NOT ACTIVATED THE BOOM GATE CLOSES AFTER 20 SECONDS ( IF DIP SWITCH 2 IS OFF).
- 7 COMMON
- 8 N/O SAFETY PE BEAM WILL HOLD OPEN PERMANENTLY WHILE BEAM IS BROKEN
- 9 COMMON
- 10 N/O LATCHED PUSH BUTTON .WHEN THE BUTTON IS ACTIVATED AND THE CIRCUIT IS CLOSED THE BOOM GATE WILL OPEN AND STAY OPEN UNTIL THE LATCHED BUTTON IS RELEASED.
- 11 COMMON
- 12 NOT USED
- 13 NOT USED
- 14 SAFETY LOOP HAS THE SAME FUNCTIONS AS THE PE BEAM
- 15 SAFETY LOOP HAS THE SAME FUNCTIONS AS THE PE BEAM
- 16 FREE EXIT LOOP (PARALLEL CIRCUIT TO T6 & T7, RAISE INPUT)
- 17 FREE EXIT LOOP (PARALLEL CIRCUIT TO T6 & T7, RAISE INPUT)
- 18 ARMING LOOP LEADER IF FITTED
- 19 ARMING LOOP LEADER IF FITTED
- 20 NOT USED
- 29 12V/DC POWER SUPPLY (+)
- 30 12V/DC POWER SUPPLY (-)

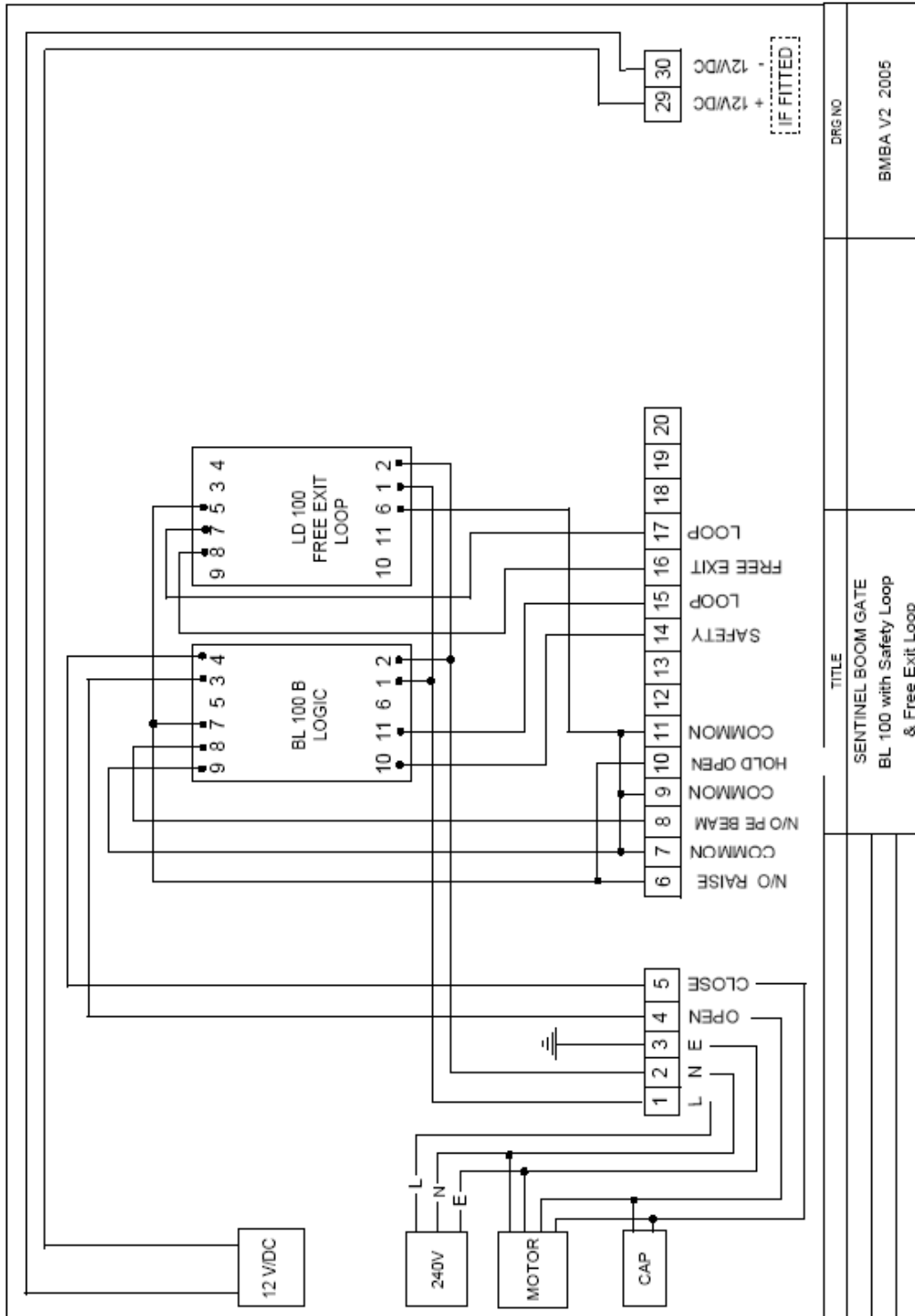

TITLE		DRG NO
SENTINEL BOOM GATE BL 100 with Safety Loop & Free Exit Loop		BMBA V2 2005

## SETTING DIP SWITCHS BL 100B

OBSERVE THE LED LIGHTS ON THE FRONT OF THE BL 100B WHILE SETTING THE DIP SWITCHES.

THE TOP LED IS THE POWER INDICATOR.

THE MIDDLE LIGHT INDICATES THAT THE BOOM IS RAISED.

### DIP SWITCH 8.

THIS IS USED TO RESET THE UNIT AND MUST ALWAYS BE RETURNED TO THE **OFF** POSITION.

### DIP SWITCH 7& 6

SET UP THE DESIRED SAFETY LOOP SENSITIVITY. THE SETTINGS CAN BE SEEN ON THE SIDE LABEL. FOR **MOST SENSITIVE** OPERATION OF 0.02% TURN 6 AND 7 DIPSWITCHES OFF

### DIP SWITCH 5.

THIS USED TO BOOST THE UNDETECT SENSITIVITY LEVEL. FOR EXAMPLE IF THE SENSITIVITY IS SET TO 1%, THEN THE UNDETECT LEVEL WILL BE 0.5% WITH THE ASB SWITCH **OFF** AND 0.02% WITH THE ASB SWITCH **ON**. LEAVE THIS SWITCH **OFF** WHERE POSSIBLE. THIS IS ONLY USED TO ENSURE HIGH BED TRUCKS STAY IN **DETECT** WHEN THE REAR SECTION OF THE TRUCK IS OVER THE LOOP.

### DIP SWITCH 4.

THE MI/NMI IS USED IN MI MODE TO ALLOW A NUMBER OF VEHICLES TO PASS THE BOOM GATE WITHOUT OPENING AND CLOSING, FOR **NORMAL OPERATION** THIS SWITCH SHOULD BE **OFF**.

### DIP SWITCH 3.

ROLL BACK TIME IS USED TO SELECT THE AMOUNT OF TIME THE LOOP STAYS ACTIVE AFTER THE BOOM GATE STARTS TO CLOSE AND IF A VEHICLE ENTERS THE LOOP WITHIN THIS TIME, THEN THE BOOM GATE WILL REOPEN UNTIL THE VEHICLE MOVES OFF THE LOOP THIS SWITCH IS NORMALLY **ON** FOR ACCESS CONTROL SITUATIONS BUT IT MAY BE NECESSARY TO SWITCH IT OFF IN HIGH VOLUME CAR PARKS TO PREVENT TAILGATING.

### DIP SWITCH 2.

CLOSE TIME, THIS DETERMINES THE AMOUNT OF TIME THE BOOM STAYS OPEN IF A VEHICLE RAISES THE BOOM THEN BACKS OUT. THIS SWITCH IS NORMALLY **ON** (NO TIMED CLOSURE) FOR ACCESS CONTROL.

### DIP SWITCH 1.

THIS CHANGES THE FREQUENCY TO PREVENT INTERFERENCE BETWEEN ADJACENT LOOPS. **OFF** FOR PAY CAR PARKS. (CLOSES AFTER 20 SECONDS)

## CONTROL LOGIC

### BMTM CONTROL PANEL (BL110 TYPICAL)

- 1 240V/AC SUPPLY
- 2 NEUTRAL
- 3 EARTH
- 4 240V **RAISE** OUTPUT TO THE MOTOR
- 5 240V **LOWER** OUTPUT TO THE MOTOR
- 6 N/O PULSE TRIGGER (CARD READER ETC.) THIS RAISES THE BOOM GATE UNTIL THE VEHICLE CLEARS THE SAFETY LOOP OR PE BEAM AND THEN CLOSES. IF THE LOOP OR PE BEAM ARE NOT ACTIVATED THE BOOM GATE CLOSES AFTER 20 SECONDS ( IF DIP SWITCH 5 IS OFF)
- 7 COMMON
- 8 N/O SAFETY PE BEAM WILL HOLD OPEN PERMANENTLY WHILE BEAM IS BROKEN. IF DIP SWITCH 4 IS OFF THE BOOM GATE WILL CLOSE IMMEDIATELY THE VEHICLE LEAVES THE SAFETY LOOP OR THE PE BEAM. WITH DIP SWITCH 4 ON, THE BOOM GATE WILL REMAIN OPEN UNTIL THE TOGGLE IS PULSED. ( T10, T11 )
- 9 COMMON
- 10 N/O PULSE PUSH BUTTON OPENS THE BOOM GATE AND A SECOND PULSE CLOSES THE BOOM GATE IF DIP SWITCH 4 IS ON.
- 11 COMMON
- 12 N/O CIRCUIT CLOSES WHEN A VEHICLE ENTERS THE ARMING LOOP. SOLID STATE TRANSISTOR RATED AT 100MA – 35VDC. +
- 13 N/O CIRCUIT CLOSES WHEN A VEHICLE ENTERS THE ARMING LOOP. SOLID STATE TRANSISTOR RATED AT 100MA – 35VDC. -
- 14 SAFETY LOOP HAS THE SAME FUNCTIONS AS THE PE BEAM
- 15 SAFETY LOOP HAS THE SAME FUNCTIONS AS THE PE BEAM
- 16 FREE EXIT LOOP (PARALLEL CIRCUIT TO T6 & T7, RAISE INPUT)
- 17 FREE EXIT LOOP (PARALLEL CIRCUIT TO T6 & T7, RAISE INPUT)
- 18 ARMING LOOP LEADER IF FITTED
- 19 ARMING LOOP LEADER IF FITTED
- 20 NOT USED
- 29 12V/DC POWER SUPPLY (+)
- 30 12V/DC POWER SUPPLY (-)

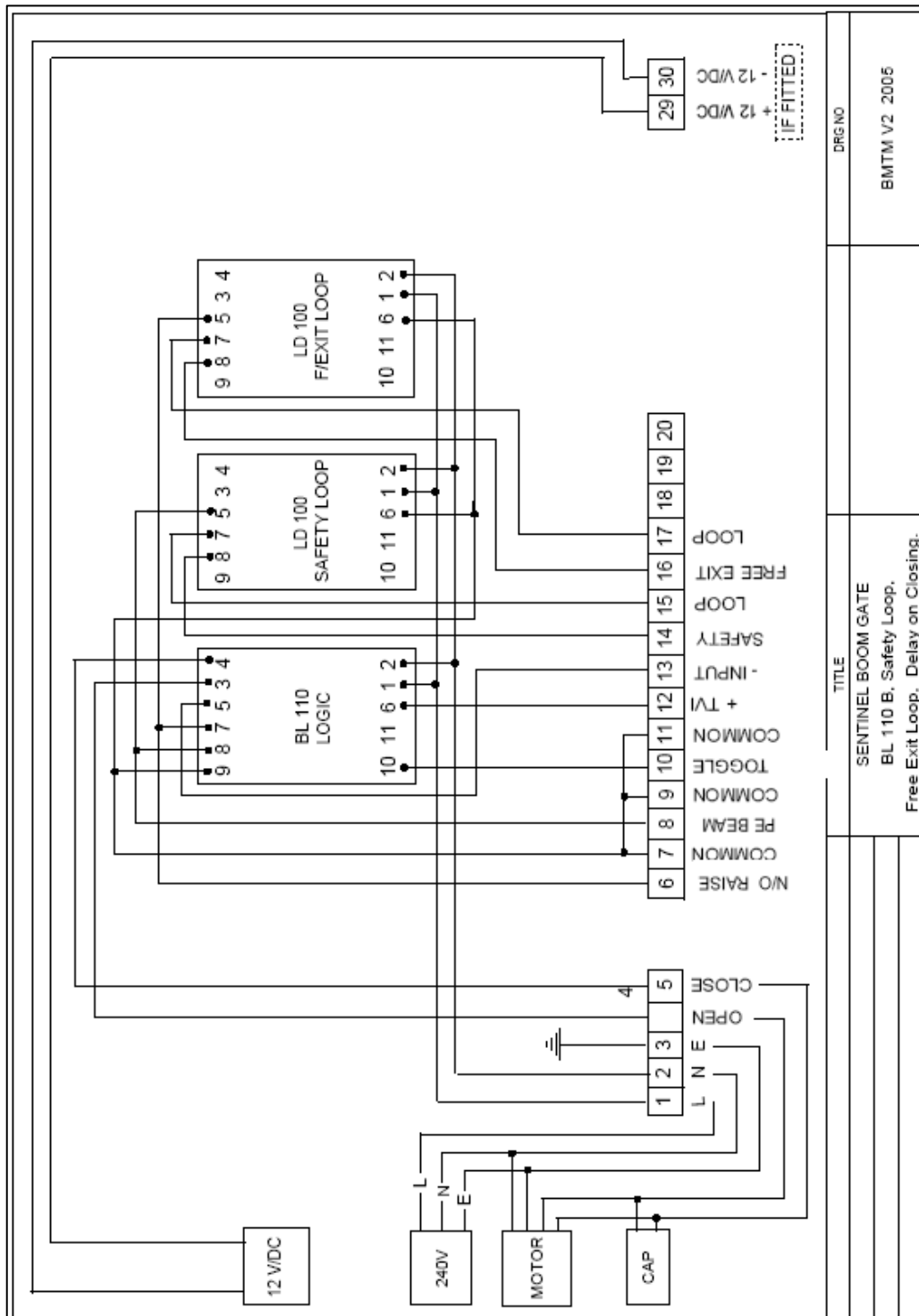

TITLE		DRG NO
SENTINEL BOOM GATE		BMTM V2 2005
BL 110 B, Safety Loop.		
Free Exit Loop. Delay on Closing.		

## SETTING DIP SWITCHS BL 110B

OBSERVE THE LED LIGHTS ON THE FRONT OF THE BL 110B WHILE SETTING THE DIP SWITCHES.

THE TOP LED IS THE POWER INDICATOR.

THE MIDDLE LIGHT INDICATES THAT THE BOOM IS RAISED.

### DIP SWITCH 8.

THIS IS USED TO RESET THE UNIT AND MUST ALWAYS BE RETURNED TO THE **OFF** POSITION.

### DIP SWITCH 7.

MI / NMI MI MODE ALLOWS A NUMBER OF VEHICLES TO PASS THE BOOM GATE WITHOUT IT OPENING OR CLOSING. FOR **NORMAL OPERATION** THIS SHOULD BE SWITCHED **OFF**.

### DIP SWITCH 6.

ROLL BACK TIME IS THE TIME THE PE BEAM OR SAFETY LOOP REMAINS ACTIVE AFTER THE VEHICLE HAS PASSED THE BOOM GATE AND IF A VEHICLE ROLLS BACK ONTO THE SAFETY LOOP OR BREAKS THE PE BEAM WITHIN THIS TIME THE BOOM GATE WILL REMAIN OPEN UNTIL THE VEHICLE IS CLEAR OF THE SAFETY LOOP OR PE BEAM. THIS DIP SWITCH IS USUALLY **ON** FOR ACCESS CONTROL SITUATIONS.

### DIP SWITCH 5.

CLOSE TIME DETERMINES THE AMOUNT OF TIME THE BOOM GATE WILL REMAIN OPEN AFTER A VEHICLE HAS CLEARED THE SAFETY LOOP OR PE BEAM. NORMALLY **ON**.

### DIP SWITCH 4.

TOGGLE **ON** ALLOWS A PULSE TO OPEN AND A PULSE TO CLOSE THE BOOM GATE. TOGGLE **OFF** ALLOWS AUTO CLOSE FROM THE SAFETY LOOP OR PE BEAM.

### DIP SWITCH 2 & 3

THESE TWO DIP SWITCHES SET REQUIRED TIME DELAY. NORMALLY **OFF** FOR NO TIME DELAY.

## FAULT FINDING

IF THE LOOP FAULT LED IS PERMANENTLY **ON** THERE IS A PROBLEM WITH THE LOOP. SOME OF THE COMMON PROBLEMS ARE:

1. THE LOOP WIRES HAVE A SHORT CIRCUIT. CHECK THE WIRING.
2. THE LOOP INDUCTANCE IS TOO LOW. MORE TURNS MUST BE ADDED TO THE LOOP.
3. THE LOOP INDUCTANCE IS TOO HIGH. THIS IS SELDOM A PROBLEM AS MOST LOOPS HAVE A INDUCTANCE OF LESS THAN 500UH. A SOLUTION IS TO REDUCE THE NUMBER OF TURNS ON THE LOOP.
4. THE LOOP IS OPEN CIRCUIT. CHECK THE WIRING.

IF THE FAULT LIGHT IS **ON** IT IS EASY TO IDENTIFY THAT THERE IS A FAULT WITH THE LOOP OR WIRING AND THIS CAN EASILY BE REPAIRED.

IF THE DETECTOR IS ERRATIC THE PROBLEM MAY BE MORE DIFFICULT TO FIND. THE FIRST STEP IS TO CHECK THE LOOP WIRING. MANY INTERMITTENT PROBLEMS CAN BE ATTRIBUTED TO POOR WIRING CONNECTIONS AND EVEN MOVEMENT IN THE LOOP. THE NEXT STEP IS TO SWITCH ON THE FREQUENCY SWITCH TO CHANGE THE LOOP FREQUENCY, AND FINALLY IT MAY BE NECESSARY REDUCE THE LOOP SENSITIVITY BY TURNING DIP SWITCHES 6 OR 7 TO ON.

CARE MUST BE GIVEN TO THE PLACEMENT OF THE LOOP. THE LOOP SHOULD NOT BE PUT BELOW REINFORCING MESH, SHOULD BE KEPT AWAY FROM ANY METAL OBJECT SUCH AS A MANHOLE AND SHOULD ALSO NOT BE WITHIN 1 METRE OF SLIDING GATES OR ROLLER DOORS.

## TESTING FREE EXIT / ARMING LOOP

1. SWITCH ON THE POWER AND OBSERVE THE LIGHTS ON THE FRONT OF THE DETECTOR.
2. THE TOP LIGHT IS AN INDICATION OF POWER. THIS LIGHT MUST ALWAYS BE **ON**.
3. THE MIDDLE LIGHT INDICATES IF THERE IS A VEHICLE PRESENT ON THE LOOP. WHEN THE POWER IS FIRST APPLIED TO THE DETECTOR THIS LIGHT FLASHES A COUPLE OF TIMES INDICATING THAT THE DETECTOR HAS TUNED TO THE LOOP. THE NUMBER OF FLASHES INDICATES THE FREQUENCY OF THE OSCILLATOR MULTIPLIED BY 10 KHZ (KILOHERTZ). FOR EXAMPLE, 7 FLASHES INDICATES THAT THE LOOP FREQUENCY IS BETWEEN 70 AND 80 KHZ. IF THIS LIGHT DOES NOT FLASH AND STAYS ON THERE IS A PROBLEM WITH THE LOOP OR WIRING.

## SETTING DIP SWITCHES LD 100

### **DIP SWITCH 10.**

MAKE SURE DIP SWITCH 10 IS **OFF**. THIS SWITCH IS USED TO EXTEND THE SIGNAL OUTPUT BY 2 SECONDS WHEN SWITCHED ON.

### **DIP SWITCHS 7, 8, 9.**

SET UP THE DESIRED SENSITIVITY ON SWITCHES 7, 8 AND 9. THE SETTINGS CAN BE SEEN ON THE SIDE LABEL. FOR THE **MOST SENSITIVE** OPERATION OF 0.02 SWITCH TURN DIP SWITCHES 7, 8 AND 9. TO **OFF**.

### **DIP SWITCH 6.**

THE FREQUENCY SWITCH 6 IS USED TO CHANGE THE LOOP FREQUENCY. IF THE LOOP DETECTOR IS EXPERIENCING INTERFERENCE FROM AN ADJACEN DETECTOR (CROSSTALK) OR FROM ANOTHER SOURCE, THE PROBLEM CAN BE ELIMINATED BY SWITCHING THIS SWITCH **ON**. FOR **NORMAL OPERATION** THIS SWITCH SHOULD BE **OFF**. LOOP OR WIRING.

### **DIP SWITCH 5**

ASB (AUTOMATIC SENSITIVITY BOOST) IS USED TO BOOST THE **UNDETECT** SENSITIVITY LEVEL. FOR EXAMPLE IF THE SENSITIVITY IS SET TO 1%, THE UNDETECT LEVEL WILL BE 0.5% WITH THE ASB SWITCH OFF AND 0.02 WITH THE ASB SWITCH ON. LEAVE THIS SWITCH **OFF** WHERE POSSIBLE. THIS IS ONLY USED TO ENSURE HIGH BED TRUCKS STAY IN **DETECT** WHEN THE REAR SECTION OF THE TRUCK IS OVER THE LOOP.

### **DIP SWITCH 4**

THE FILTER IS USED TO DELAY THE SWITCHING ON OF THE DETECTOR WHEN A VEHICLE MOVES ONTO THE LOOP. THIS SWITCH IS NORMALLY **OFF**.

### **DIP SWITCH 3.**

THE PERMANENT PRESENCE IS USED WHEN THE LOOP DETECTOR MUST DETECT A VEHICLE FOR DAYS AT A TIME. FOR EXAMPLE IN A PARKING BAY. THIS SWITCH IS NORMALLY **OFF**.

### **DIP SWITCH 2.**

THE PULSE MODE IS USED TO CONFIGURE THE PULSE RELAY. WHEN THIS SWITCHED **OFF** THE PULSE RELAY WILL PULSE ON AND OFF WHEN A VEHICLE **ENTERS** THE LOOP. WHEN THIS SWITCH IS SWITCHED **ON** THE PULSE RELAY WILL PULSE ON AND OFF WHEN A VEHICLE **LEAVES** THE LOOP.

### **DIP SWITCH 1.**

THE PULSE TIME IS USED TO EXTEND THE DURATION OF THE PULSE RELAY. THIS DIP SWITCH IS NORMALLY **OFF**. WHEN SWITCHED OFF THE PULSE DURATION IS 0.2 SECONDS AND WHEN THE SWITCH IS ON THE PULSE DURATION IS 1 SECOND.

**NOTE : AFTER CHANGES TO THE SETTINGS PRESS THE RESET BUTTON.**

## FITTING BOOM GATE ARTICULATED ARM

**BOOM POLES ARE SUPPLIED IN 3, 4.5, OR 6 METRE LENGTHS.**

1. DRILL 8MM HOLES IN CABINET AS SHOWN IN FIG.1. FIT THE SUPPORT BRACKET TO THE BOOM GATE CABINET WITH THE HARDWARE SUPPLIED.

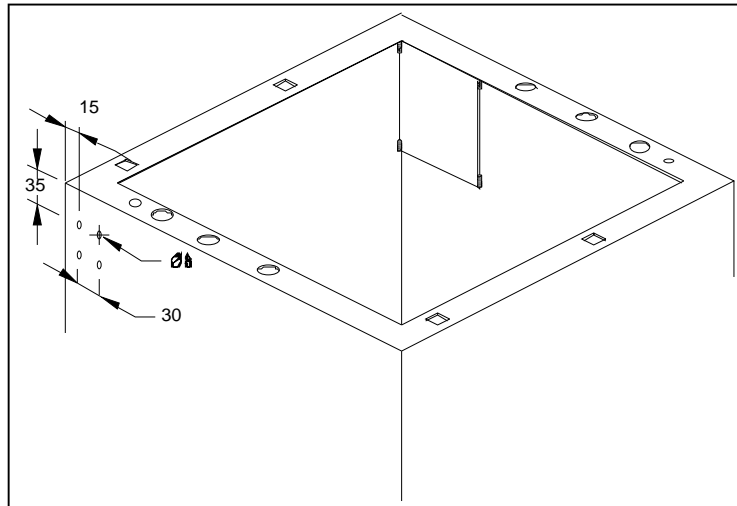

2. CUT BOOM POLE **A** USING THE FORMULA BELOW.  
 $MC = \text{MAXIMUM CLEARANCE.} \quad MC = VH + VCH.$   
 $VCH = \text{VEHICLE CLEARANCE HEIGHT.}$   
 $VH = \text{VEHICLE HEIGHT.}$   
 LENGTH POLE **A.**  $MC - 1215 = A$   
 E.G.(MAX. CLEARANCE = 2800.)  $2800 - 1215 = \mathbf{1585MM.}$
3. RELEASE SPRING TENSION BY UNDOING THE TOP NUT TO THE END OF THE THREADED ROD ON EACH SPRING.
4. SWITCH POWER **ON** AND USING THE TOGGLE CONTROL ON THE FRONT OF THE LOGIC CONTROL MODULE POSITION THE BOOM IN THE DOWN POSITION. FIT POLE **A** INTO THE BOOM CLAMP AND TIGHTEN.
5. FIT THE ARTICULATED ARM TO THE OTHER END OF BOOM POLE **A**.  
**NOTE** - USE MASKING TAPE TO HOLD THE JOINTS TOGETHER WHILE SETTING UP.
6. FIT THE TURNBUCKLE ASSEMBLY TO THE CABINET SIDE OF THE CABINET SUPPORT BRACKET MIDWAY DOWN THE SLOT AND TIGHTEN SO THE ASSEMBLY WILL STILL SWIVEL.
7. FIT THE UPPER ROD CLAMP TO THE ARTICULATED ARM AND TIGHTEN SO THAT THE CLAMP WILL STILL SWIVEL FREELY.
8. FIT THE 6MM ROD INTO THE UPPER ROD CLAMP AND TIGHTEN ALL GRUB SCREWS.
9. ALIGN THE ROD WITH THE TURNBUCKLE ASSEMBLY AND WITH THE ARTICULATED ARM IN THE HORIZONTAL POSITION MARK THE ROD AT THE END OF THE TURNBUCKLE ASSEMBLY AND CUT 25MM LONGER. AFTER CUTTING PLACE THE ROD IN THE TURNBUCKLE ASSEMBLY AND TIGHTEN ALL GRUB SCREWS.

10. CUT POLE **B** TO SUIT ENTRANCE WIDTH AND FIT TO THE ARTICULATED ARM.
11. LEVEL POLE **B** WITH POLE **A** BY ADJUSTING THE TURNBUCKLE THEN TIGHTENING BOTH LOCK NUTS.
12. TOGGLE BOOM GATE TO THE OPEN POSITION.
13. LEVEL POLE **B** BY ADJUSTING THE HEIGHT OF THE TURNBUCKLE ASSEMBLY THE SLOT ON THE CABINET SUPPORT BRACKET.

**DO NOT ADJUST THE TURNBUCKLE.**

14. RETENTION SPRINGS AS PER SECTION ON PAGE.
15. CHECK BOOM IS LEVEL IN THE OPEN AND CLOSED POSITIONS. TOGGLE BOOM TO THE CLOSED POSITION AND FIX POLE A & B TO THE ARTICULATED ARM, (INSURING THAT THE ARTICULATED ARM IS VERTICAL) BY EITHER RIVETS OR SELF DRILLING SCREWS AND REMOVE ALL MASKING TAPE.

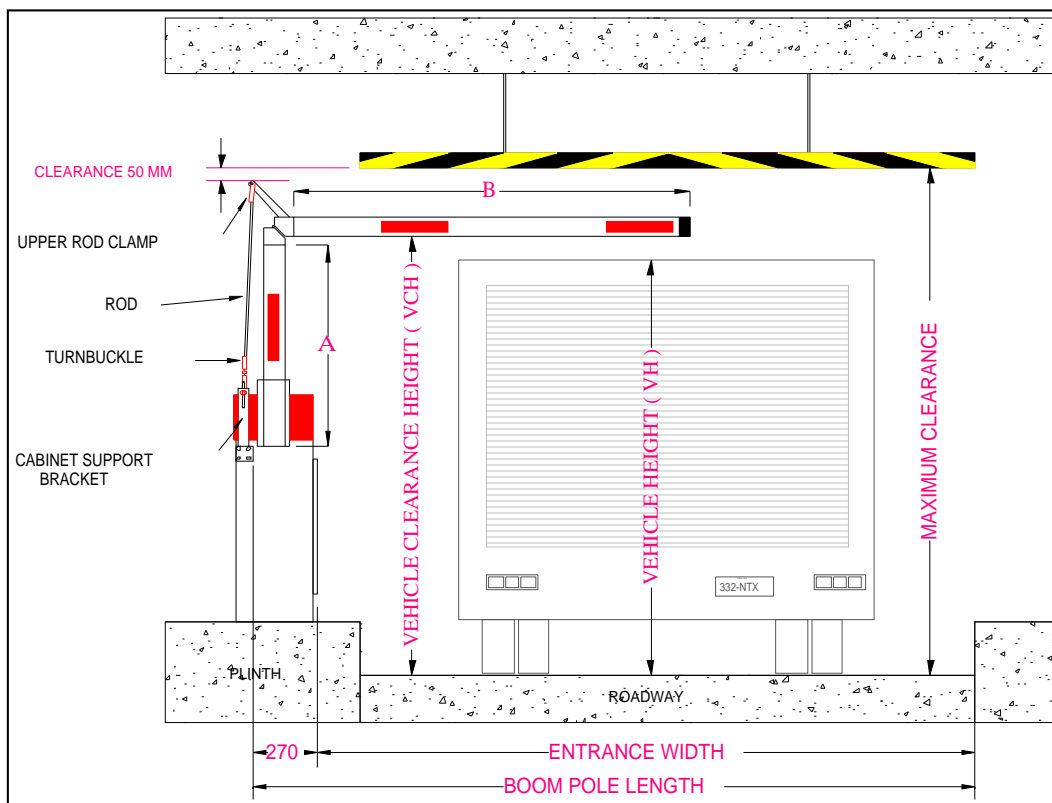

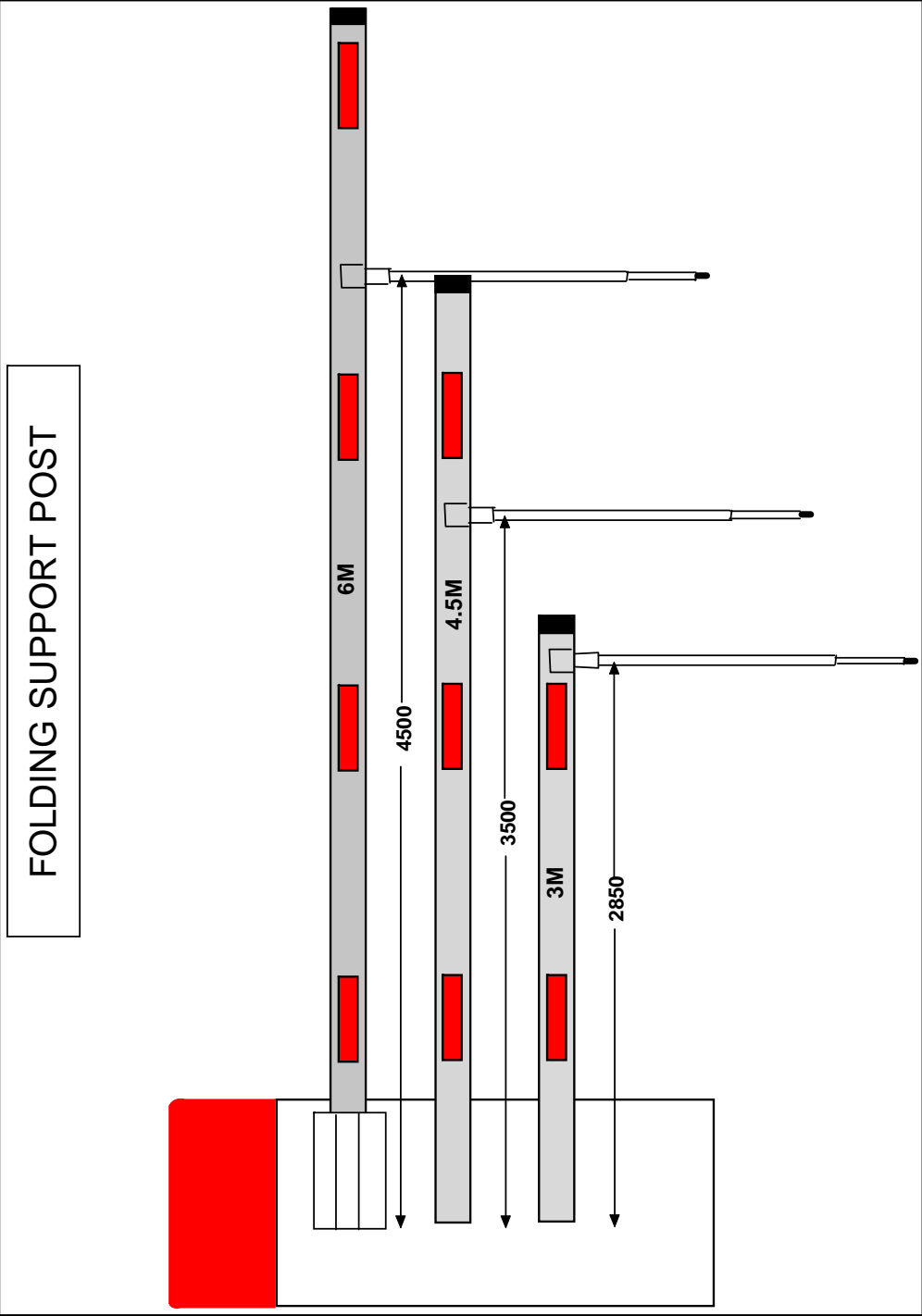

## **FOLDING SUPPORT POST**

IF THE FOLDING SUPPORT POST HAS BEEN SUPPLIED WITH A BOOM GATE FROM THE MANUFACTURER ALL SPRINGS ARE PRESET.

IF THE FOLDING POST HAS BEEN SUPPLIED TO FIT TO AN EXISTING BOOM GATE THEN THE SPRINGS NEED TO BE CHANGED AND ADJUSTED AS SHOWN BELOW.

<b><u>SIZE</u></b>	<b><u>SPRING TYPE</u></b>	<b><u>QTY</u></b>
3.0	HEAVY DUTY	1
4.5	HEAVY DUTY	2
6.0	HEAVY DUTY	3

FIT THE FOLDING SUPPORT POST AT THE FOLLOWING DISTANCE

<b>3.0 M POLE</b>	2850 MM FROM THE END OF POLE TO THE CENTRE OF THE POST BRACKET.
<b>4.5 M POLE</b>	3500 MM FROM THE END OF POLE TO THE CENTRE OF THE POST BRACKET.
<b>6.0 M POLE</b>	4500 MM FROM THE END OF POLE TO THE CENTRE OF THE POST BRACKET.

FIT FOLDING SUPPORT POST TO BOOM POLE AND ADJUST SPRINGS AS IN INSTALLATION INSTRUCTIONS PAGE 3.

TOGGLE THE BOOM GATE TO THE CLOSED POSITION.

ADJUST BOOM POLE FOR LEVEL BY ADJUSTING THE ADJUSTABLE ARM ON THE MOTOR BASE AND COMPRESSING THE GAS STRUT ON THE FOLDING SUPPORT POST BY 50 MM ENSURING THE BOOM POLE IS STILL LEVEL.

THE FOLDING POST SHOULD BE ADJUSTED BY SLIDING THE LOWER INNER TUBE UP OR DOWN TO COMPENSATE FOR THE DIFFERENCE IN HEIGHT BETWEEN THE BOOM GATE AND THE SURFACE OF THE ROAD.

INITIALLY ONLY TIGHTEN ONE GRUB SCREW. WHEN THE BOOM GATE CLOSES THE SHOCK ABSORBER SHOULD COMPRESS AND HOLD THE BOOM POLE IN THE HORIZONTAL POSITION.

WHEN THE ADJUSTMENTS HAVE BEEN COMPLETED LOCK BOTH GRUB SCREWS IN POSITION.

<b>BOOMGATE SPARES</b>	
<b>CODE</b>	<b>DESCRIPTION</b>
5762	Rod end RH
5761	Rod end LH
5778	Aluminium motor arm
5776	Adjustable arm
583	Hard Stop 16mm
573	TM 10 Motor
574	TM 5.5 Motor
5200	NV Red Top Cover Only
52113	Empty Cabinet & Cover
5204	NV S/S Red Top Cover Only
52114	Empty S/S Cabinet & Cover
5208	Boom Clamp & SS Bolts
5209	Hold Down Bar Only
52091	Hold Down Tube Only
5639	Red Decals
52111	Danger Decals
52112	Keep Hands Clear Decal
5775	Boom Coupler
52115	NV Lock & Latch
52116	NV Spare Key (Each)
52117	NV Black Hinges
	<b><u>Boom Poles</u></b>
564	3m
565	4.5m
566	6m

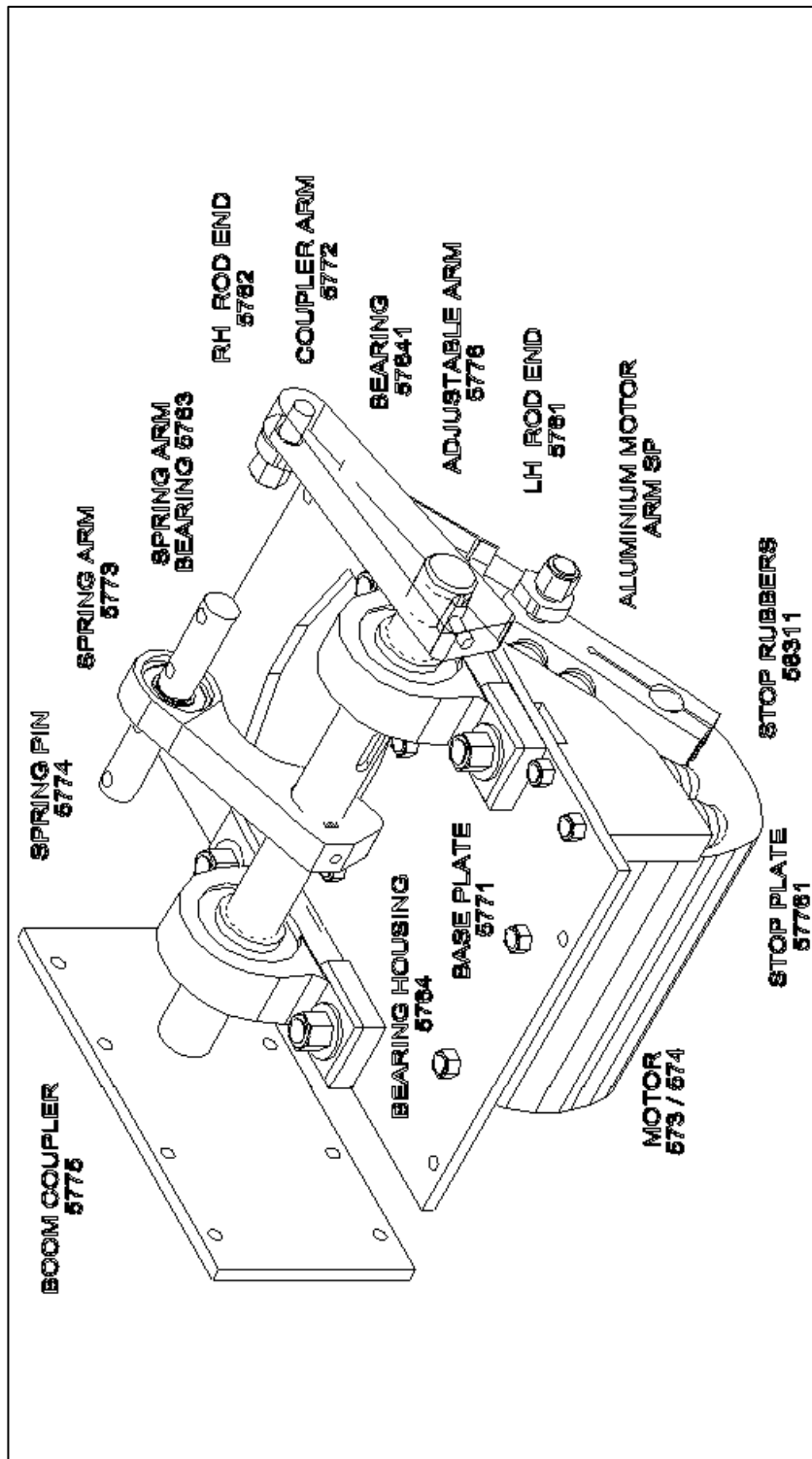

## SERVICE INSTRUCTIONS – SENTINEL BOOM GATES

### WARNING

**BOOMGATE OPERATES AUTOMATICALLY.  
ISOLATE POWER BEFORE SERVICING.**

1. THE SENTINEL NV SERIES BOOM GATES NEED TO BE SERVICED EVERY 6 MONTHS IN HIGH VOLUME INSTALLATIONS AND EVERY 12 MONTHS IN LOW VOLUME INSTALLATIONS.
2. INSPECT THE CABINET FOR ANY SIGNS OF DAMAGE; CLEAN WITH A MINERAL CLEAN AND REPAIR ANY PAINT DAMAGE WITH A ZINC BASED PAINT.
3. OPERATE THE BOOM GATE AND OBSERVE THE MOTION OF THE BOOM POLE. IF THE POLE DIPS AS IT STARTS TO OPEN THE ALUMINIUM MOTOR ARM HAS GONE OVER CENTRE, REPLACE WORN STOP RUBBERS AND CHECK MOTOR ARM FOR ALIGNMENT. LEVEL POLE AS IN SECTION 5 IF REQUIRED.
4. TEST SPRING TENSION.  
LOWER THE BOOM POLE WITH POWER **ON**. THEN SWITCH POWER **OFF**. THE BOOM POLE SHOULD RISE TO THE FULLY OPEN POSITION SMOOTHLY AND REMAIN OPEN. IF THE POLE DOES NOT OPEN FULLY THEN MORE TENSION IS REQUIRED ON EACH SPRING. IF THE POLE OPENS VIOLENTLY THEN LESS SPRING TENSION IS REQUIRED.
5. CHECK THE POSITION OF THE BOOM POLE. IF IT IS NOT LEVEL ADJUST THE ADJUSTABLE ARM UNTIL IT IS LEVEL. AFTER ADJUSTMENT, CHECK THAT THE ADJUSTABLE ARM IS IN LINE WITH THE ALUMINIUM MOTOR ARM WHEN THE BOOM POLE IS IN THE DOWN POSITION. TEST BY TRYING TO LIFT THE BOOM POLE UP WITH POWER **ON**. PROPERLY ADJUSTED YOU SHOULD **NOT** BE ABLE TO OPEN THE BOOM GATE.
7. CHECK STOP RUBBERS FOR CRACKS OR WEAR AND REPLACE IF NECESSARY.
8. CHECK THE CABINET HOLD DOWN BARS ARE SECURE AND THAT THE CONCRETE SURFACE IS IN GOOD REPAIR.
9. CHECK AND TIGHTEN ALL BOLTS, GRUB SCREWS AND MECHANICAL FIXINGS.
10. CHECK AND TIGHTEN ALL ELECTRICAL CONNECTIONS. INSPECT LEADS AND CABLES FOR DAMAGE. REPLACE AS REQUIRED.
11. CHECK THAT THE LOOP CABLES ARE TWISTED TIGHTLY TOGETHER.
12. CHECK AND CLEAN ANY LUBRICANT FROM AROUND MOTOR OUTPUT SHAFT.
13. CHECK CONDITION OF ROADWAY AND LOOP SEALING.

## NOTES

