



CENTURION
THE AUTOMATIC CHOICE

Smart 2
SYSTEM

REMOTE RECEIVER

CENTURION SMART is a remote control system using "self-learning" technology making it very quick and easy to set up. Each transmitter has a unique code obviating the need to set dip switches. With no 2 codes alike, the system is very secure. SMART 2 is fully compatible with all existing SMART equipment. For the best results, we recommend that the receiver be mounted as high up as possible, and preferably away from metal objects and other radio equipment. The receiver enclosure is weatherproof, but any holes drilled during installation should be properly sealed. The antenna wire has been tuned to an optimum length, and should not be modified.

CONFIGURING THE SYSTEM:

Transmitter:

Each transmitter is uniquely coded at the factory. **It is NOT necessary to open the transmitter, except when changing the battery.** To replace the battery, rotate the inner casing, and remove from the outer clip. Using a coin, prise apart the inner casing to expose the battery. Replace with type GP23 or similar.

Receiver:

Open the receiver housing by inserting a screwdriver into the slot at the base and twisting (See diagram overleaf).

For pulsed operation:

- 1) Locate the "LEARN" pins. **WITH POWER ON, bridge the two pins with the shunt provided. The red LED will now illuminate.**
- 2) Press the required button on the transmitter. The red LED will flash once, indicating that the button has been learned as a momentary button. If the red LED flashes rapidly, the memory is full, and the button cannot be memorised.
- 3) If further buttons are to be memorised, repeat from step 2. If not, remove the bridge from the "LEARN" pins. The system is now ready for use.

For latched operation:

- 1) Locate the "ERASE" pins. **WITH POWER OFF, bridge the two pins with the shunt provided. Power up the unit. The red LED will now illuminate.**
- 2) Press the required button on the transmitter. The red LED will flash twice, indicating that the button has been learned as a latched button. If the red LED flashes rapidly, the memory is full, and the button cannot be memorised.
- 3) If further buttons are to be memorised, repeat from step 2. If not, remove the bridge from the "ERASE" pins. The system is now ready for use.

Note

- 1) *When programming a multi button transmitter to a multi channel receiver, button 1 will operate channel 1, button 2 channel 2 etc.*
- 2) *The single channel receiver is capable of memorizing up to 125 buttons. The multi channel receiver is capable of memorizing up to 500 buttons.*

Erasing the memory:

With power on, the memory may be erased by bridging the "ERASE" pins with the shunt provided. The red LED will begin to flash. During this time, removing the shunt will cancel the erase process. After twelve flashes, the red LED will remain illuminated. Remove the shunt, and the red LED will flash rapidly as the memory is erased.

WARNING: This procedure will remove all existing users from the system memory.

Autolearn mode: (Pulsed operation only)

The receiver can be set into autolearn mode by bridging the "Learn" pins **PRIOR to applying power.** Each valid signal received in this mode will both activate the contact, AND be stored in memory. This is useful when setting up systems with a large number of transmitters. The system can be left in autolearn mode for a period of time, and will automatically memorise the transmitters as they are used. Removing the jumper will cancel the autolearn mode. NOTE: When using autolearn mode, any SMART transmitters in the nearby vicinity will be memorised. This MAY include transmitters used in other nearby areas.

Received signal indicator:

If a signal is received from an unauthorized button, the red LED will flash briefly. This indicates that the transmitter is functioning, but has not been learned into the system.



CENTURION
THE AUTOMATIC CHOICE

INSTALLATION INSTRUCTIONS

REMOVE COVER

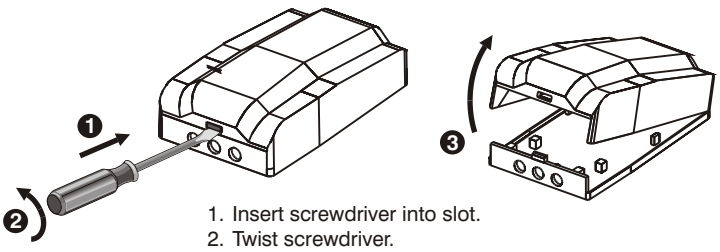

MOUNT UNIT

1. Mark position of unit against mounting surface.
2. Using a 5mm masonry bit, drill holes into mounting surface
3. Mount the unit using the fasteners supplied.

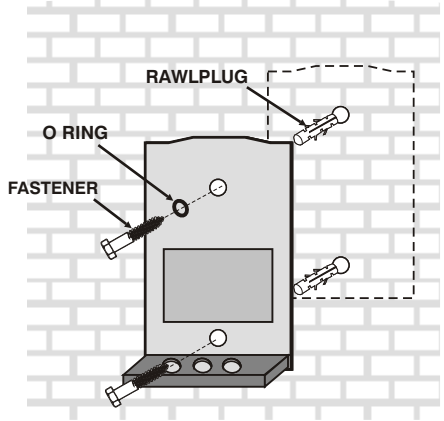

WIRING

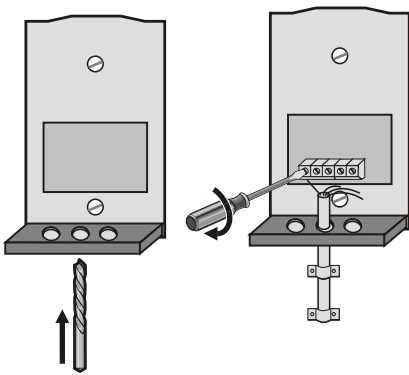

1. Use a 6mm drill bit to open the required cable entry hole.
2. Fix cable to wall using cable saddles.
3. Seal all holes with silicon sealant.

CONNECTIONS

1. Supply the unit with 12-24V AC/DC.
2. The output contact is potential free. Some applications might require an external link between NEG and COM.
3. Extend the antenna wire fully for best results.

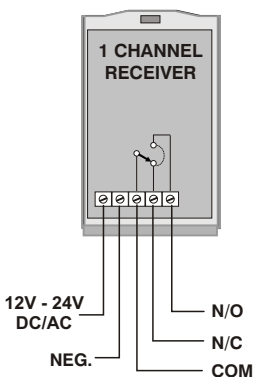
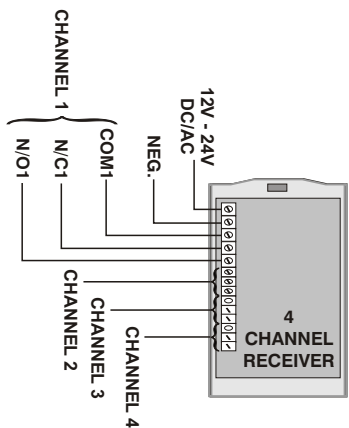

REPLACE COVER

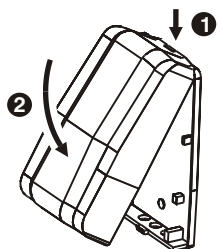

1. Hook the top edge of the cover onto the top of the unit.
2. Lower the cover and press securely into position.