

Installation and operating instructions

Controller MO 36

for swing gate operators

with 24Vdc motors with pulser

General of notes safety	4
1. Usage	5
2. Electrical Installation	5
3. Connection plan of the controller MO36	6
3.1. Connections	7
3.1.1. Input terminals	7
3.1.2. Buttons on the controller	7
3.1.3. LEDs on the controller	7
3.1.4. Output terminals	8
4. Programming MO36	8
4.1. Learning sequence	8
4.1.1. Sequence P1: Learning of the running distance	9
4.1.2. Sequence P2: Adjusting of force and speed	10
4.1.3. Sequence P3: Time lag of the pedestrian wing (closing)	10
4.1.4. Sequence P4: Time lag of the main wing (opening)	11
4.1.5. Sequence P5: Learning and deleting of code for radio remote control for BT, BTG and MULTI	11
4.1.6. Sequence P6: Automatic closure for complete opening	11
4.1.7. Sequence P7: Automatic closure for pedestrian wing	12
4.1.8. Sequence P8: Warning prior to opening and closing	13
4.1.9. Sequence P9: Photo-cell function	14
4.1.10. Sequence PA: Photo-cell testing	15
4.1.11. Sequence PB: Lockage function for the photo-cells	16
4.1.12. Sequence PC: Pressure relief of electromechanical bolt	17
4.1.13. Sequence PD: Wind blast suppression	17
4.1.14. Sequence PE: Multi-functional relay	18
4.1.15. Sequence PF: Return to original settings	18
5. Safety contact profiles for gate open (SLA) and close (SLZ)	18
6. Additional functions and additional modules	19
6.1. Timer module ASU2 (optional)	19
6.2. Traffic light module AMO34A (optional)	20
7. Power failure	20
8. Fault diagnosis	21
8.1. Error code on the display	21
8.2. Emergency mode	21
9. Technical Data MO36	22
9.1. Selection range of Parameter and Original settings	22

Safety relevant rules and regulations

The swing gate controller MO36 has been developed and manufactured according to EN12453 Industrial commercial and garage doors and gates – Safety in use of power operated doors - Requirements. All notes in this instruction have to be obeyed by the user. All work and repairs on electrical appliances must be carried out by qualified persons only. They have to be knowledgeable about the relevant regulations. They have to be able to recognise possible safety hazards and take necessary safety actions. The operational safety of the controller MO36 is only guaranteed during usage as intended.

During installation, initial operation phase, maintenance and testing of the controller the individually relevant regulations for safety and accident prevention have to be obeyed.

These are the following directives and standards: (list is not necessarily complete):

- EN12445: Industrial commercial and garage doors and gates – Safety in use of power operated doors – Test methods
- EN12453: Industrial commercial and garage doors and gates – Safety in use of power operated doors - Requirements
- EN60335-1: Household and similar electrical appliances – Safety –Part 1: General requirements

Power supply: 230Vac, 50Hz, single phase.

Connection: By fixed wiring and main switch (on site) or flexible wiring with cable stress relief device according European standards.

Symbol's:



WARNING! Danger of harm to people and objects



INFORMATION! Important information for installation and operation



REMARK! Remarks for the installation

General of notes safety

These operating instructions must be available on site at all times. It should be read thoroughly by all persons who use, or service the appliances. Improper usage or servicing or ignoring the operating instructions can be a source of danger for persons, or result in material damage. If the meaning of any part of these instructions isn't clear, then please contact ELKA Torantriebe GmbH u. Co. Betriebs KG before you use the appliance.

This applies to all setup procedures, fault finding, disposal of material, care and servicing of the appliance.

The accident prevention regulations and applicable technical regulations (e.g. safety or electrical) and environment protection regulations of the country in which the appliance is used also apply.

All repairs on the appliances must be carried out by qualified persons. ELKA Torantriebe GmbH u. Co. Betriebs KG accepts no liability for damage which is caused by using the appliance for purposes other than those for which it is built.

ELKA Torantriebe GmbH u. Co. Betriebs KG cannot recognise every possible source of danger in advance. If the appliance is used other than in the recommended manner, the user must ascertain that no danger for himself or others will result from this use. He should also ascertain that the planned use will have no detrimental effect on the appliance itself. The appliance should only be used when all safety equipment is available and in working order. All faults which could be a source of danger to the user or to third persons must be eliminated immediately. All warning and safety notices on the appliances must be kept legible.

All electrical periphery equipment which is connected to the appliance must have a CE Mark, which ensures that it conforms to the relevant EEC regulations. Neither mechanical nor electrical alterations to the appliance, without explicit agreement of the manufacturer, are allowed. All alterations or extensions to the appliance must be carried out with parts which ELKA Torantriebe GmbH u. Co. Betriebs KG have defined as suitable for such alterations, and be carried out by qualified personnel.

Any contravention of these conditions revokes the manufacturer's guarantee and also the CE Mark and the user is alone responsible for the consequences.

Our service department is available to answer all queries about these conditions and, of course, about our appliances.

The operation of the system within CEN countries must also be conformant with the European safety-relevant directives and standards.
--

We reserve the right to make technical improvements without prior notice.

1. Usage

The MO36 is a controller for swing gate operators for gates with one or two wings with 24Vdc motors with pulser and with end stoppers.

For gate with two wings (two operators, one controller): when using both wings, the pedestrian wing opens shortly before the main wing. When the gate closes the controller makes sure, that the main wing arrives at the end position CLOSED first and the pedestrian wing second.

2. Electrical Installation

For swing gate openers with radio remote control the controller MO36 should be installed as close as possible to the gate. The control box should be mounted with the entrance for wiring at the bottom.

The lead from controller to motor should have at least the cross section stated below. A smaller gauge will have adverse effect on the motor performance.

Cross section: **5 x 1,5 mm²** up to max. **20 m**

Cross section: **5 x 2,5 mm²** up to max. **40 m**

Power supply: 230Vac, 50Hz, single phase.

Connection: By fixed wiring and main switch (on site) or flexible wiring with cable stress relief device according to European standards.

i

For the connection motor – controller please use a suitable cable, possibly with a mechanical protection (conduit). To avoid mistakes please use marked (colour) or numbered leads within the 5-leads cable.

3. Connection plan of the controller MO36



Each safety contact strip terminal which is not used has to be linked to an 8.2 kΩ resistor.

Each photo-cell and stop terminal which is not used has to be linked to a jumper.

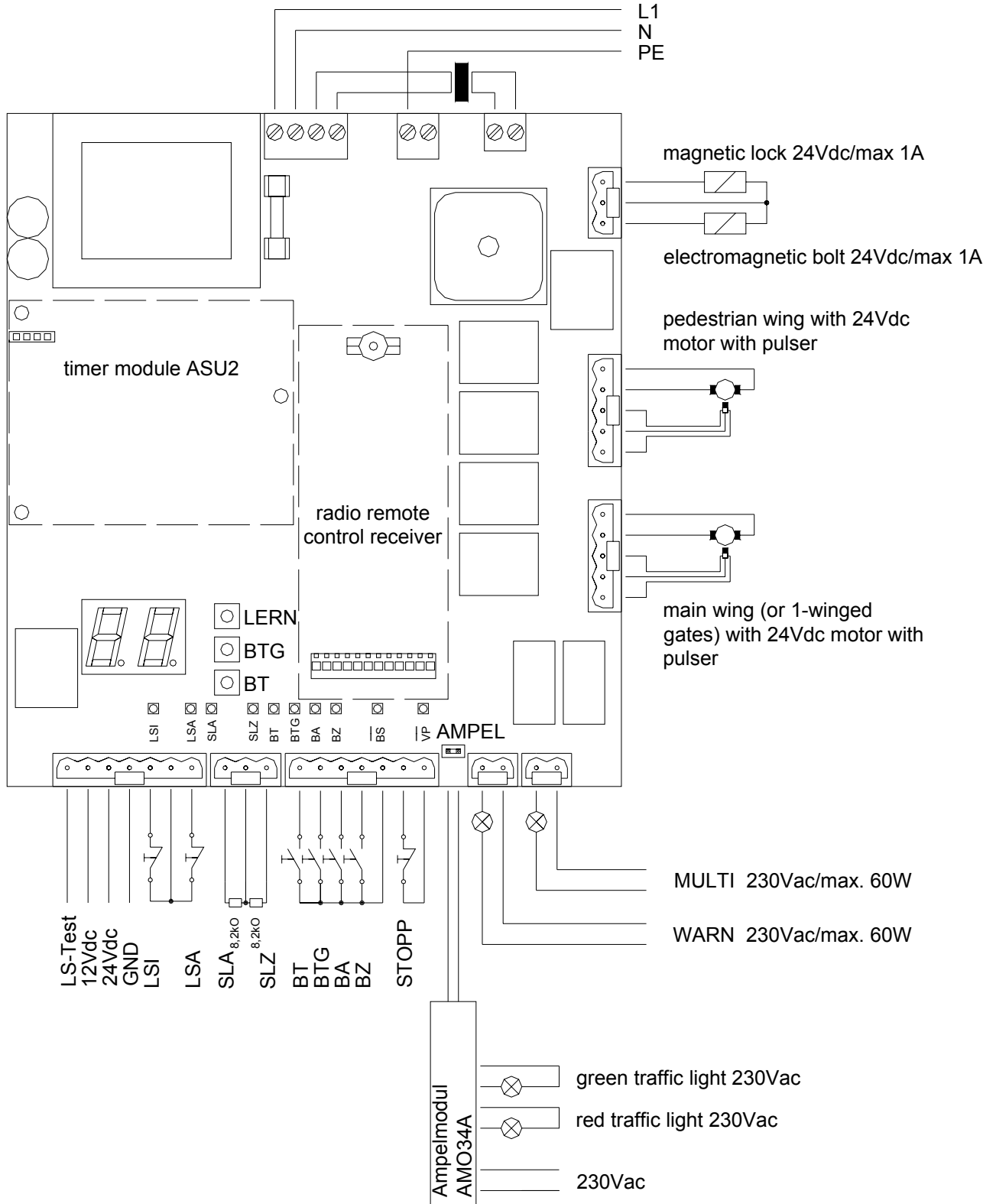

Drawing 1

3.1. Connections

3.1.1. Input terminals

Input	Ausführung	Connection	Function
BT	n.o. contact	1 pin	Push button (serial switching)
BTG	n.o. contact	1 pin	Push button for pedestrian opening
BA	n.o. contact	1 pin	Push button OPEN
BZ	n.o. contact	1 pin	Push button CLOSE
Ground	-	1 pin	Mutual ground BT, BTG, BA u. BZ
LSA LSI	Each max. 6 photo-cells with n.c. contact and terminating resistor 1kΩ	2 pin	Photo-cells for installation outside (LSA) and inside (LSI) - (according to EN954-1 category 2)
Ground	-	1 pin	Mutual ground LSA and LSI
SLA SLZ	safety contact profile: a) resistor detection – b) n.c. contact with 8.2kΩ resistor (serial or parallel with n.o. contact with 8.2 kOhm)	2 pin	Integrated detectors with testing function (according to EN954-1 category 2) for safety contact profile for gate OPEN (SLA) and CLOSE (SLZ)
Ground	-	1 pin	Mutual ground SLA and SLZ
IMP _g	pulser	See motor	Pulser for pedestrian wing
IMP _f	pulser	See motor	Pulser for main wing
SU		Plug socket	Connection for timer module ASU2
Funk		Plug socket for receiver EKX10F or receiver with decoder	Integrated receiver for BT, BTG and MULTI
Mains (L1, N, PE)	-	3 pin	Power supply 230Vac – L1, N and PE

Table 1

3.1.2. Buttons on the controller

Mark	Function
BT	Same function as external button BT
BTG	Same function as external button BTG
LERN	Starting the learning mode

Table 2

3.1.3. LEDs on the controller

Mark	Colour	Function	Desired value
Vp	Yellow	lights when connected to main power	ON
SLA	Red	Lights, when safety contact profile SLA active	OFF
SLZ	Red	Lights, when safety contact profile SLZ active	OFF
BT	Green	Lights, when the contact is closed	OFF, when pushing button = ON
BTG	Green	Lights, when the contact is closed	OFF, when pushing button = ON
BA	Green	Lights, when the contact is closed	OFF, when pushing button = ON
BZ	Green	Lights, when the contact is closed	OFF, when pushing button = ON
BS	Green	Lights, when the contact is closed	ON
LSA	Green	Lights, when LSA is interrupted	OFF
LSI	Green	Lights, when LSI is interrupted	OFF
Display	Red	2 x 7-segment-display	OFF

Table 3

3.1.4. Output terminals

Output	Connection	Corresponds to:
Motor pedestrian wing and IMP _g	5-pol.	Connection for 24Vdc motor and pulser for the pedestrian wing
Motor main wing and IMP _f	5-pol.	Connection for 24Vdc Motor and pulser for the main wing or for one-winged gates
SCHLOSS	3-pol.	Connection for electromechanical bolt or magnetic lock with 24Vdc (max. 1A)
WARN	2-pol.	Potential-free contact for warning light 230Vac / max. 60W
MULTI	2-pol.	Potential-free contact for multi-functional relays (230Vac / max. 60W)
Uext	3-pol.	24Vdc and 12Vdc, mutual ground terminal, stabilised direct voltage, together max. 300mA, ground terminal is connected with controller ground
LS-TEST	1-pol.	24Vdc for photo-cell transmitter
PE	1-pol.	earth
AMPEL	2-pol.	socket for traffic light modulel AMO34A red / grün

Table 4

4. Programming MO36

For programming and to set operating parameters, use the two-digit 7-segment display and the buttons BT, BTG and LERN.

4.1. Learning sequence

During normal operation the display is off. The learning sequence is activated by pushing the button LERN for approx. 2s. The display shows **P1**. The sequence 1 is pre-set. With the button **BT** you can move on to the next sequence P2, P3 etc.

With the button **BTG** you can move back to the last sequence. When the required sequence is displayed it has to be activated with the button LERN.

Sequence	Function
P1	<ul style="list-style-type: none"> - Selection one wing / two wings - Adjusting of end stops - Learning of safety contact profiles and photo-cells connected - Learning of running distance
P2	Adjusting of force and speed
P3	Adjusting of time lag of the pedestrian wing during closing
P4	Adjusting of time lag of main wing during opening
P5	Learning and deleting of codes radio remote control for BT, BTG and MULTI
P6	Automatic closure for complete opening (for both wings) <ul style="list-style-type: none"> - activating / deactivating - change stay-open time
P7	Automatic closure for pedestrian wing <ul style="list-style-type: none"> - activating / deactivating - change stay-open time
P8	Selecting of warning prior to opening and closing
P9	Selecting of photo-cell function
PA	Activating / deactivating photo-cell testing
PB	Activating / deactivating lockage function for photo-cells
PC	Selecting pressure relief of electromechanical bolt
PD	Selecting wind blast suppression
PE	Selecting mode of multi-functional relay
PF	Return to original settings
PP	Saving of data and returning to regular mode

Table 5

4.1.1. Sequence P1: Learning of the running distance

When sequence P1 has been activated, it has to be selected first between gates with one (1F) or two (2F) wings using button BT. Then confirm the selection with button LERN.

Display	Effect / Function
1F	To operate gates with one wing
2F	To operate gates with two wings

Table 6

Then **HA** is displayed. The gate wings now can be operated by dead man's motion using buttons BT or BTG to adjust the internal mechanical end stoppers (when using openers like TERRA or ZENIT). BT is used for the main wing and BTG for the pedestrian wing. The first direction is always OPEN.



Attention! During learning the safety devices may act different from the regular operation. Please ensure that no people are in the danger area during learning.

After adjusting the end stoppers, push the button LERN to continue: The controller tests the safety contact strips and the photo-cells. It learns the type of the safety contact strips (FRABA or 8.2 kOhm) and the number of connected photo-cells. Only when this photo-cell testing was successful, additional photo-cell tests can be carried out during future operation.

Gates with one wing:

During learning of the running distance the wing opens first and then closes.

Gates with two wings:

During learning of the running distance the pedestrian wing opens, the main wing opens, the main wing closes, pedestrian wing closes.

In both cases the wings move until they hit the stoppers at the closed position.

During the learning of the running distance the pressure relief of the electromechanical bolt is not in function. The electromechanical bolt is being activated during each wing movement.

After the learning of the running distance, returning to the main sequence follows automatically.



Remark: After adjustment of the end stoppers, the wings should not be in either end position but at least 50cm before. The first movement is into direction open.

4.1.2. Sequence P2: Adjusting of force and speed

The force and speed can be adjusted for each wing separately, and for opening and closing separately. When sequence P2 is activated by button LERN an additional selection menu for force and speed opens. With button BT you may move to different points of the selection menu.

Sub-sequence	Function
F1	Force for opening of main wing (2-winged gates) / the wing (1-winged gates)
F2	Force for closing of main wing (2-winged gates) / the wing (1-winged gates)
F3	Force for opening of pedestrian wing. No function with 1-winged gates.
F4	Force for closing of pedestrian wing. No function with 1-winged gates.
S1	Speed for opening of main wing (2-winged gates) / the wing (1-winged gates)
S2	Speed for closing of main wing (2-winged gates) / the wing (1-winged gates)
S3	Speed for opening of pedestrian wing. No function with 1-winged gates.
S4	Speed for closing of pedestrian wing. No function with 1-winged gates.

Table 7

With the button LERN the selected point can be activated. The present value for force (F = force) or speed (S = speed) is displayed. Possible values are **01** (for minimum force) up to **99** (for maximum force) or **01** (for minimum speed) up to **08** (for maximum speed). With button LERN the values may be increased, with the button **BTG** they can be decreased. Return to the learning sequence using button LERN.



Attention: The maximum force (F1 - F4) has to be adjusted according to the relevant gate opener using the learning sequence. If a force higher than shown below (table 12) is adjusted, the motor will not be able to reverse on obstacle.

Swing gate opener	Adjustment range
ZENIT / TERRA 280/282	F1 – F4 = max. 35
ZENIT / TERRA 350/352	F1 – F4 = max. 55
ZENIT / TERRA 420/422	F1 – F4 = max. 75
ED 180/182	F1 – F4 = max. 35
KOMET 200 / 202	F1 – F4 = max. 35
KOMET 280 / 282	F1 – F4 = max. 35
KOMET 400 / 402	F1 – F4 = max. 45
KOMET 600 / 602	F1 – F4 = max. 55
ROLLER 1/2	F1 – F4 = max. 35 (maximum speed S1 – S4 = max. 5)

Table 8

4.1.3. Sequence P3: Time lag of the pedestrian wing (closing)

When sequence **P3** is activated by button **LERN**, the present value for the time lag of the pedestrian wing during closing is displayed. Possible values are **00** (for 0s) up to **09** (for 9s). The value can be increased using button **BT** and decreased using button **BTG**. Return to the learning sequence using button **LERN**.



Remark: When a time lag is selected for gates with one wing, it will not be in effect.

4.1.4. Sequence P4: Time lag of the main wing (opening)

When sequence **P4** is activated by button **LERN**, the present value for the time lag of the pedestrian wing during closing is displayed. Possible values are **00** (for 0s) up to **09** (for 9s). The value can be increased using button **BT** and decreased using button **BTG**. Return to the learning sequence using button **LERN**.



Remark: When a time lag is selected for gates with one wing, it will not be in effect.

4.1.5. Sequence P5: Learning and deleting of code for radio remote control for BT, BTG and MULTI

To learn a code the transmitter has to be operated. The code will then be stored. When sequence **P5** is activated with the button **LERN**, an additional selection menu is displayed for selecting the code. Move to the next point using button **BT**.

Sub-sequence	Function
C1	Radio remote control code for BT can be learned or deleted
C2	Radio remote control code for BTG can be learned or deleted
C3	Radio remote control code for MULTI can be learned or deleted
Next	Return to main sequence

Table 9

Sub-sequence is activated with button **LERN**. The display shows:

Display	Corresponds to:
--	The selected radio remote control code is deleted and another can be learned.
oo	The selected radio remote control code is already stored and can be overwritten or deleted

Table 10

To erase the radio remote control code, press and hold the button **BT** and additionally push the button **LERN**. The radio remote control code is erased. Return to the sub sequence follows automatically. If only the button **LERN** is pushed, then return to the sub sequence follows immediately without erasing the code.

Radio remote control signal:

Receiving of a learned radio remote control signal is displayed through lighting of the right display dot.

4.1.6. Sequence P6: Automatic closure for complete opening

When sequence **P6** is activated by button **LERN**, the present value for stay-open time for complete opening is displayed. Possible values are -- (not activated), **01** up to **299** (for 1s - 299s). The value can be increased using button **BT** and decreased using button **BTG**. The decimal dots of the display are each equal to 100 (one lit dot = 100 / two lit dots = 200).

Display (example)	Corresponds to:
--	Automatic closure is deactivated.
23	Automatic closure is activated. Stay-open time 23 seconds.
23.	Automatic closure is activated. Stay-open time 123 seconds.
2.3.	Automatic closure is activated. Stay-open time 223 seconds.

Table 11

Return to the learning sequence using button **LERN**.

When using automatic closure both wings close automatically after the learned stay-open time has elapsed. The stay-open time starts elapsing when the last wing has reached the position OPEN.

- When contact BS is opened, the automatic closure function is blocked.
- When the stay-open time has elapsed and the safety contact profile for direction CLOSE (SLZ) is currently activated, the gate remains open. The elapsed stay-open time will not be repeated. When the SLZ is not activated anymore and the stay-open time has elapsed, the warning time prior to closing starts.
- When the automatic closure function is blocked it will be reactivated with a new signal (BA or BT).
- When the lockage function for the photo-cells is activated, the automatic closure function is blocked, as long as an obstacle is present between the photo-cells (see sequence PB).
- When the gate hits an obstacle during closing and reversing is activated through SLZ, the gate opens. When automatic closure is activated and the obstacle is not removed, the gate will try to close twice. After hitting the obstacle for the second time the gate will reverse for a short distance and stop.
- The counting will be erased when using BT, BA, or BZ.

4.1.7. Sequence P7: Automatic closure for pedestrian wing

When sequence **P7** is activated by button **LERN**, the present value for stay-open time for the pedestrian wing is displayed. Possible values are -- (not activated), **01** up to **299** (for 1s - 299s). The value can be increased using button **BT** and decreased using button **BTG**.

The decimal dots of the display are each equal to 100 (one lit dot = 100 / two lit dots = 200).

Display (example)	Corresponds to:
--	Automatic closure is deactivated.
23	Automatic closure is activated. Stay-open time 23 seconds.
23.	Automatic closure is activated. Stay-open time 123 seconds.
2.3.	Automatic closure is activated. Stay-open time 223 seconds.

Table 12

Return to learning sequence using button **LERN**.

When using automatic closure the pedestrian wing closes automatically after the learned stay-open time has elapsed. The stay-open time starts elapsing when the wing has reached the position OPEN.

- When contact BS is opened, the automatic closure function is blocked.
- When the stay-open time has elapsed and the safety contact profile for direction CLOSE (SLZ) is currently activated, the gate remains open. The elapsed stay-open time will not be repeated. When the SLZ is not activated anymore and the stay-open time has elapsed, the warning time prior to closing starts.
- When the automatic closure function is blocked it will be reactivated with a new signal (BA or BT).
- When the lockage function for the photo-cells is activated, the automatic closure function is blocked, as long as an obstacle is present between the photo-cells. (See sequence PB)

- When the gate hits an obstacle during closing and reversing is activated through SLZ, the gate opens. When automatic closure is activated and the obstacle is not removed, the gate will try to close twice. After hitting the obstacle for the second time the gate will reverse for a short distance and stop.
- The counting will be erased when using BT, BA, or BZ.

4.1.8. Sequence P8: Warning prior to opening and closing

When sequence **P8** is activated by button **LERN**, the present value for warning time (opening and closing) is displayed. With the button **BT** the value can be selected (see table).

Return to the learning sequence using button **LERN**.

The warning light is only active, when a gate wing is moving and during warning prior to opening and closing.

Display	Warning time before opening	Warning time before closing
00	No warning time	No warning time
04	No warning time	4 seconds warning time
40	4 seconds warning time	No warning time
44	4 seconds warning time	4 seconds warning time

Table 13

4.1.9. Sequence P9: Photo-cell function

When sequence **P9** is activated by button **LERN**, the present selection for the photo-cell function is displayed. With the button **BT** the value can be selected (see table). Return to the learning sequence using button **LERN**.

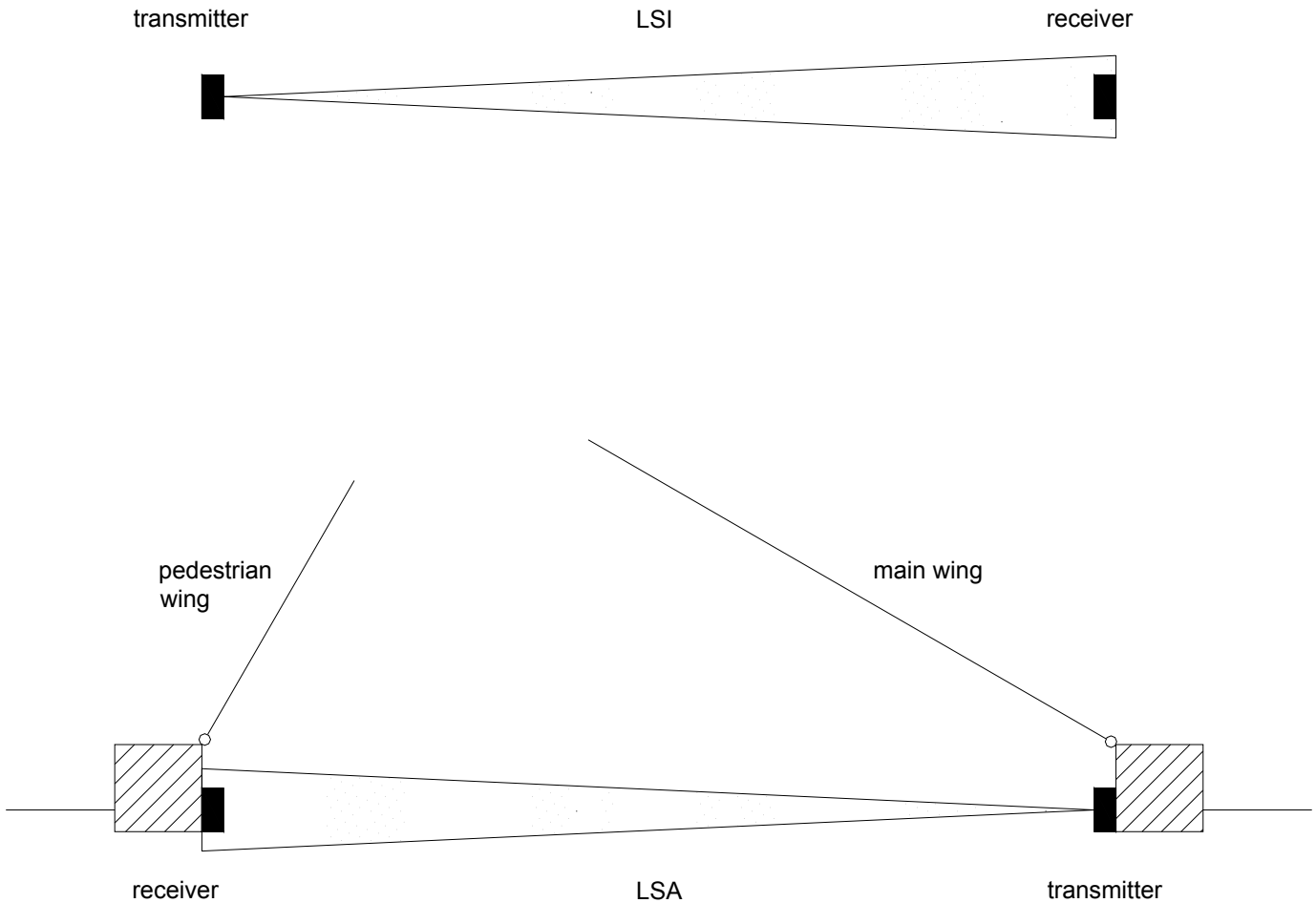

Drawing 2

Function	Photo-cell	Gate not moving	Gate opens	Gate closes
L1	LSI	Remains not moving	Stops when interrupted, opens when free again	Stops when interrupted, opens when free again
	LSA	Remains not moving	Stops when interrupted, opens when free again	Stops when interrupted, opens when free again
L2	LSI	Remains not moving	Stops when interrupted, opens when free again	Stops when interrupted, closes when free again
	LSA	Remains not moving	Stops when interrupted, opens when free again	Stops when interrupted, closes when free again
L3	LSI	Only closing allowed	Stops when interrupted, opens when free again	No effect
	LSA	Only opening allowed	No effect	stops and opens immediately

Table 14

4.1.10. Sequence PA: Photo-cell testing

Prior to every gate movement a photocell test may be performed. The test consists of two phases. During the first phase the supply of the transmitters is switched off. The controller expects within the next 2.5 s that the receiver reports an obstacle.

During the second phase the supply of the transmitter is switched on again. The controller expects the receiver to report no obstacle any more. Only after this procedure the gate can move.

If an error occurs in the first phase, the photocell (receiver) is damaged. The gate will not move. An error message is given through the display. If an error occurs in the second phase, the controller interprets this as a real obstacle. The gate will not move. No error message is given.

You may connect and test each (LSI and LSA) maximum 6 pairs of photocells with the controller MO36. Therefore add all n.c. relay contacts of the receivers in serial. Parallel to each relay contact you must add a 1 kΩ resistor (Resistors are needed only when photocell test is used).

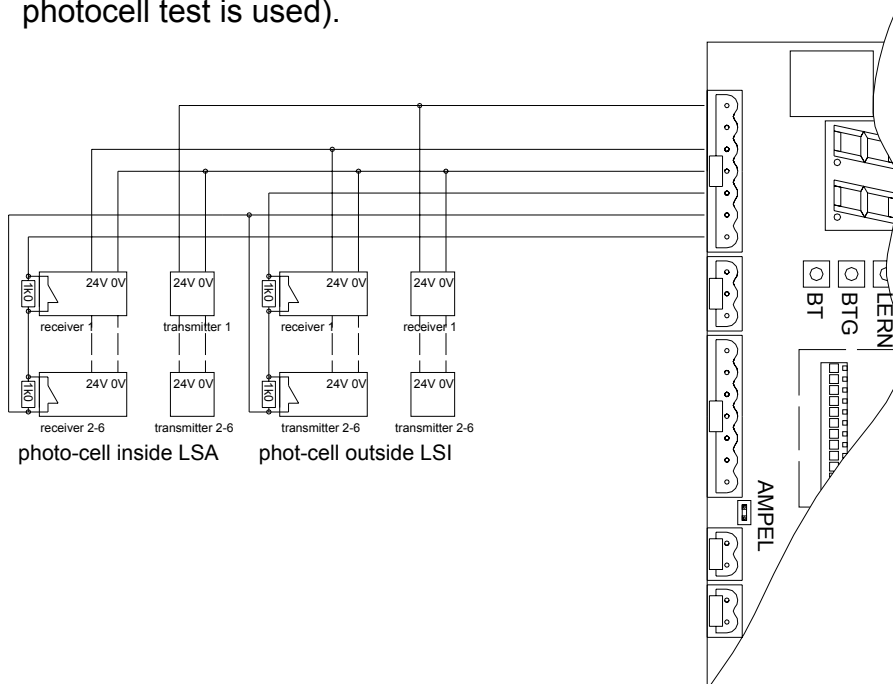

Drawing 3



The MO 36 must learn how many photocells are connected to it. Activate the test by setting **PA = ON** and run the learning of the running distance P1.

After this please check every single photocell for proper function.



Remark! When a faulty photo-cell is detected during photo-cell testing or when an obstacle is present within the photo-cell, the gate can be opened and closed in emergency mode (dead man's function).

When sequence **PA** is activated by button **LERN**, the present selection for the photo-cell testing is displayed. With the button **BT** the value can be selected (see table).

Return to the learning sequence using button **LERN**.

Display	Corresponds to:
oF	Photo-cell testing deactivated
On	Photo-cells, which have past the LS-Test during sequence P1, will execute photo-cell testing also in regular mode.

Table 15

4.1.11. Sequence PB: Lockage function for the photo-cells

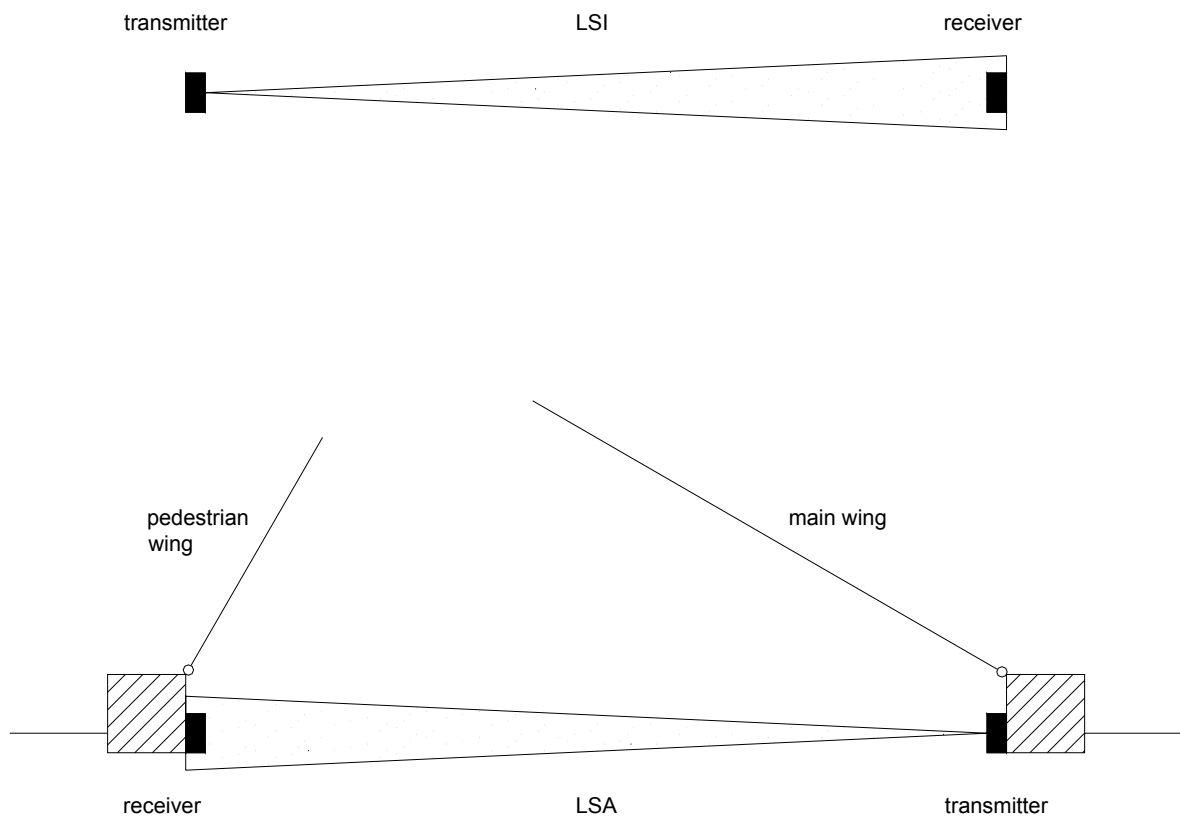

Drawing 4

When using photo-cells in connection with the automatic closure for both wings, a lockage function is possible. To activate this function use the learning sequence.

- The lockage function is only activated when the gate is opened.
- When the gate reaches the end position OPEN, the lockage function is initialised. This means: when a vehicle passes through the gate from the outside, a signal from LSA (photo-cell outside) blocks the automatic closure function. Only the signal from LSI (photo-cell inside) removes the blocking and starts the stay-open time. When a vehicle passes through the gate from the inside, a signal from LSI blocks the automatic closure function. Only the signal from LSA removes the blocking and starts the stay-open time.

When sequence **PB** is activated by button **LERN**, the present selection is displayed. With the button **BT** the value can be selected (see table).

Return to the learning sequence using button **LERN**.

Display	Corresponds to:
oF	Lockage function is deactivated.
On	Lockage function is activated (only working when automatic closure is selected.) When the photo-cell is interrupted, closing of the gate wing / wings is only possible, when the vehicle / person has passed both (LSA and LSI) photo-cells.

Table 16

4.1.12. Sequence PC: Pressure relief of electromechanical bolt

When sequence **PC** is activated by button **LERN**, the present selection is displayed. With the button **BT** the value can be selected (see table).
Return to the learning sequence using button **LERN**.

Display	Corresponds to:
S1	Pressure relief for electromagnetic bolt is deactivated.
S2	The gate wing pushes slowly 500ms min., but 1000ms max., against the end stopper until the selected force is reached.
S3	The gate wing pushes slowly 500ms min., but 2000ms max., against the end stopper until the selected force is reached.
S4	The gate wing pushes slowly 500ms min., but 90s max., against the end stopper until the selected force is reached.

Table 17



Information (for S4 only): Is pressure relief **S4** selected and the end stopper is not reached within 90s, then the gate stops (running time limit) and the controller blocks itself.

4.1.13. Sequence PD: Wind blast suppression

It can be chosen to either reverse on obstacle immediately, or to reverse after a preset time. When setting a time, a short wind blast or an oscillating gate wing do not result in a stop (and reversal).



Warning: Only use the wind blast suppression, when additional safety devices like photo-cells and safety contact profiles are installed at the gate.

When sequence **PD** is activated by button **LERN**, the present selection is displayed. With the button **BT** the value can be selected (see table).
Return to the learning sequence using button **LERN**.

Display	Corresponds to:
U -	No wind blast suppression. The controller immediately reacts on obstacle/wind blast.
U1 - U9	The wind blast suppression equals 1s (for U1) up to 9s (for U9). The controller reacts on obstacle / wind blast only after the selected time 1s (for U1) up to 9s (for U9).

Table 18

4.1.14. Sequence PE: Multi-functional relay

The multi-functional relay on the controller is suitable for four different modes. During learning function the relay is inactive.

When sequence **PE** is activated by button **LERN**, the present selection is displayed. With the button **BT** the value can be selected (see table).

Return to the learning sequence using button **LERN**.

Display	Corresponds to:
r1	Push button mode: The relay is active as long as the controller receives the radio remote control code MULTI.
r2	Toggle mode: The relay alternates between active and inactive with each radio remote control code MULTI.
r3	Light pulse mode: The relay is active for 1 second, when BT, Funk BT, BTG, Funk BTG, BA or BZ are pushed.
r4	3-minute light: The relay is active for 180 seconds, when BT, Funk BT, BTG, Funk BTG, BA or BZ are pushed.

Table 19

4.1.15. Sequence PF: Return to original settings

When sequence **PF** is activated by button **LERN**, **rE** is displayed. To return to original settings, press and hold button **BT** and push button **LERN**. When only button **LERN** is pushed, you return to learning sequence without changing any values. After returning to original settings, the running distance has to be relearned.

5. Safety contact profiles for gate open (SLA) and close (SLZ)



Gates with two wings: When a safety contact profile is activated, both motors react.

The controller has two integrated detectors with testing function (according to EN954-1 category 2 for safety contact profiles with 8.2kOhm resistor) for gate OPEN and CLOSE.

The status of the safety contact profiles is displayed by red LEDs (SLA and SLZ). When the safety contact profile is activated, the matching LED lights.

Direction of movement	Function of SLA	Function of SLZ
From stop to open	Only possible in emergency mode	-
From stop to closing	-	Only possible in emergency mode
Opening	Stop and movement for a short distance direction closed	-
Closing	-	Stop and re-opening

Table 20

Note: see counting function for reversing (4.1.6.2).

The connection of the n.o. contact with $8.2k\Omega \pm 5\%$ resistor (parallel) or the n.c. contact with $8.2k\Omega \pm 5\%$ resistor (serial) is possible. In case no safety contact profiles are connected, an $8.2k\Omega \pm 5\%$ resistor has to be connected.
 When using more than one safety contact profile, they can be connected in sequence (see drawing below).

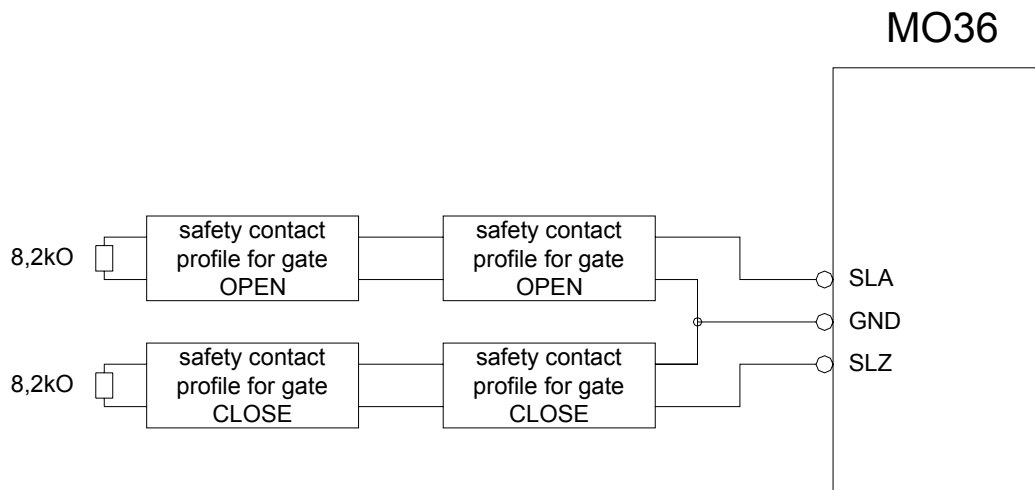

Drawing 5

6. Additional functions and additional modules

6.1. Timer module ASU2 (optional)

The timer module can be plugged onto the controller. Function: When the timer has reached the set time for open, it sends an OPEN command to the controller. The gate cannot be closed as long as the timer is activated. After the open time has elapsed, the timer sends a CLOSE command to the controller.

Note: When the timer sends the CLOSE command, the gate is closed immediately, even when automatic closure is activated.

6.2. Traffic light module AMO34A (optional)

Red and / or green traffic lights can be connected to the traffic light module.

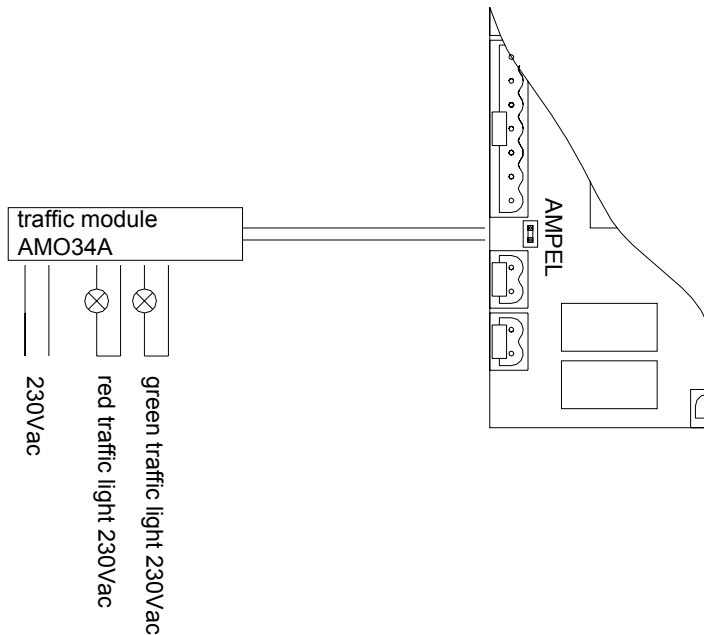

Drawing 6

Gate position	Red traffic light	Green traffic light
Gate is completely open	Off	On
Gate is not open (it is moving, partially open, or closed)	On	Off

Table 21

7. Power failure

After power failure or disconnecting from mains the position of the wing/wings is unknown to the controller. The controller first works in a starting mode. The wings are moving slowly. A pressure relief of electromechanical bolt occurs before every movement. The wings close one after the other. When stopping at the end position (closed), the controller recognises this position. The controller continues in its regular mode.

Note: Emergency mode is possible during the starting mode.

8. Fault diagnosis

8.1. Error code on the display

An error is shown on the display as a code, when detected by the controller. The following errors are recognised and displayed.

Display	Error
E1	Photo-cell testing LSI failed
E2	Photo-cell testing LSA failed
E3	Testing safety contact profile SLA failed
E4	Testing safety contact profile SLZ failed
E5	Running distance exceeded (gate was stopped). Check end stoppers and re-learn the running distance.
E6	The power supply limit for the external equipment 12V has been reached. The power source load is too high. The controller is blocked.
E7	The power supply limit for the external equipment 24V has been reached. The power source load is too high. The controller is blocked.
E8	The memory data has been lost / is faulty. The controller has to be re-learned.
E9	Error in storing of data on memory. Controller is faulty. Return for repairs.
EA	Error in the redundant detection of BS. Controller is faulty. Return for repairs.
EB	The controller detects one of motor relays is faulty. Return for repairs.
EC	Measuring amplifier faulty. Send the controller back to your dealer.
ED	The main wing pulser is faulty. Check the wiring between the opener and controller.
EE	The pedestrian wing pulser is faulty. Check the wiring between the opener and controller.
EF	Power supply Uext has a short cut. OR At least one wing is released. Check the emergency release.

Table 22

8.2. Emergency mode

In case a safety device (LSA, LSI, SLA or SLZ) is faulty, emergency mode is possible. After a warning time of 10 seconds, the gate can be moved in an emergency mode by using BA or BZ (dead man's function). During the warning time as well as during the emergency mode the warning light is flashing. Emergency mode by radio remote control (BT or BTG) is not possible due to safety reasons.



Warning! Even when a safety device is faulty, the gate can be moved by BA and BZ. The buttons BA and BZ therefore have to be installed in such a way, that the gate can be seen during movement.



Warning! Are external devices -giving a constant signal (e.g. timer)- connected to BA or BZ, these devices can activate the emergency mode and move the gate when a safety feature is faulty or active.



Warning! In case the multi-functional relay is used for an additional radio remote channel, which is connected to BA or BZ, the emergency mode can be started by radio remote control. In this case only fixed transmitter should be used in such a way, that the gate can be seen during movement.

9. Technical Data MO36

9.1. Selection range of Parameter and Original settings

Constant, not changeable values	
Parameter	Original settings
Time-lag before reactivating motor	500ms
Reversing for a short distance on obstacle	500ms
Time-lag before reversing	200ms
Max. running time limit	500s
Running time reserve during regular mode	10s
Warning time prior to emergency mode	10s

Changeable values		
Parameter	Selection range	Original settings
Running distance	Max. 32.000 Impulse	3.000 Impulse
Force	1 - 99	30
Speed	Level 1 - 8	Level 8
Time lag during opening	0s - 9s	2s
Time lag during closing	0s - 9s	5s
Stay-open time for both wings	1s - 299s / OFF	OFF
Stay-open-time for pedestrian wing	1s - 299s / OFF	OFF
Wind blast suppression	0s - 9s	0s
Warning prior to opening	0s or 4s	0s
Warning prior to closing	0s or 4s	0s
Pressure relief of electromagnetic bolt	0s / 1s / 2s / 90s	0s
Multi-functional relay	Push button mode / Toggle mode / Light pulse / 3-minute-light	Push button mode
LS lockage function	ON / OFF	OFF
Photo-cell function	L1 or L2 or L3	L1
Number of wings	1 / 2	1
Photo-cell testing	ON / OFF	OFF
Type of safety contact profile	8,2kΩ or FRABA	8,2kΩ
Radio remote control code BT	X-code	- + - + - + -
All other radio remote control codes	X-code	deleted