

Bulwark DB Series Boom Gate

240 vac boom gate



While the Bulwark DB series does not have the many features of the Sentinel NV series it is excellent value and is suited to more basic applications.

Bulwark DB boom gate has a compact modern design and is suitable for medium sized car parks, factory entrances and office complexes (max 700 operations per day).

The robust designed sinusoidal mechanism ensures a smooth operation and safety devices such as safety loop detectors, PE safety beams and radio controls can be fitted.

- The opening speed is 3 seconds on the 3 metre and 6 seconds on the 5 metre. The opening and closing positions are easy to set and are accurately monitored by magnetic limit switches.
- The control panel is mounted under the top cover in a sealed enclosure and is easy to access and commission, a 24vdc 1 amp power supply is standard.
- The control panel has numerous inputs and 2 relay outputs that are programmable via dip switches for status indication, traffic lights and flashing lights.
- Electrical connection is made from a standard Australian 3 pin plug.
- The cabinet is treated with an anti corrosion phosphate compound and then painted white, the boom pole is 76 mm diameter and is supplied with 3M red reflective decals.

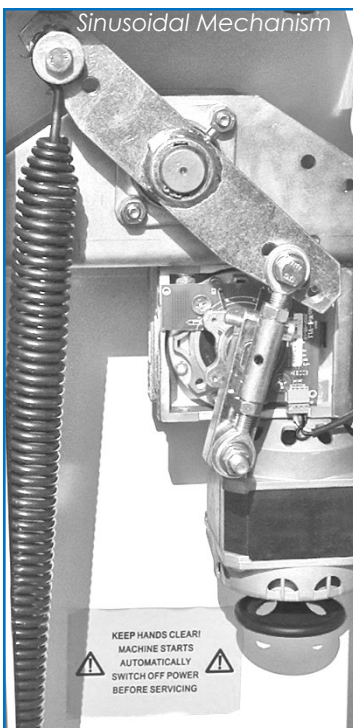

Technical Specifications

Specifications	Bulwark DB Series
Power Supply	240 vac
Motor	90 w
Noise	≤60dB
Opening Speed	3 sec (3m) 6 sec (5m)
Pole	76 dia
Pole Length	3 - 5 m
Dimensions	360mm x 240mm x 1140mm
Weight	65 KG
Temperature	-25°C ~ 70°C
Humidity	<90%

Dimensions

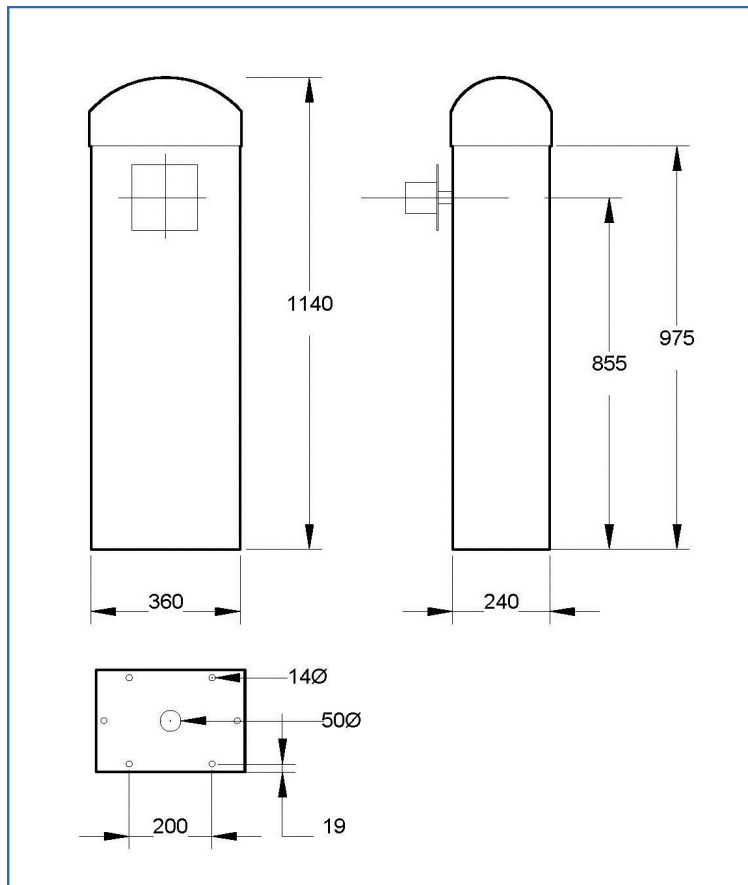

Rotech supply all forms of door and gate automation

Vehicle Access Control

- Booms Gates
- Sliding Gates
- Swing Gates
- Industrial Door Openers
- Solar Powered Gate Openers

Pedestrian Access Control

- Full Height Turnstiles
- Waist Height Turnstiles
- Supermarket Gates/Turnstiles
- Wheelchair Access Gates
- Rapid Access Gates

Fast | Safe | Secure