



Vehicle Access Control
Pedestrian Access Control
Safety & Security Equipment

T: +61 7 3205 1123

www.rotech.com.au

e: info@rotech.com.au

SENTINEL AG SERIES BOOM GATE

Installation Instructions V1 (0317)

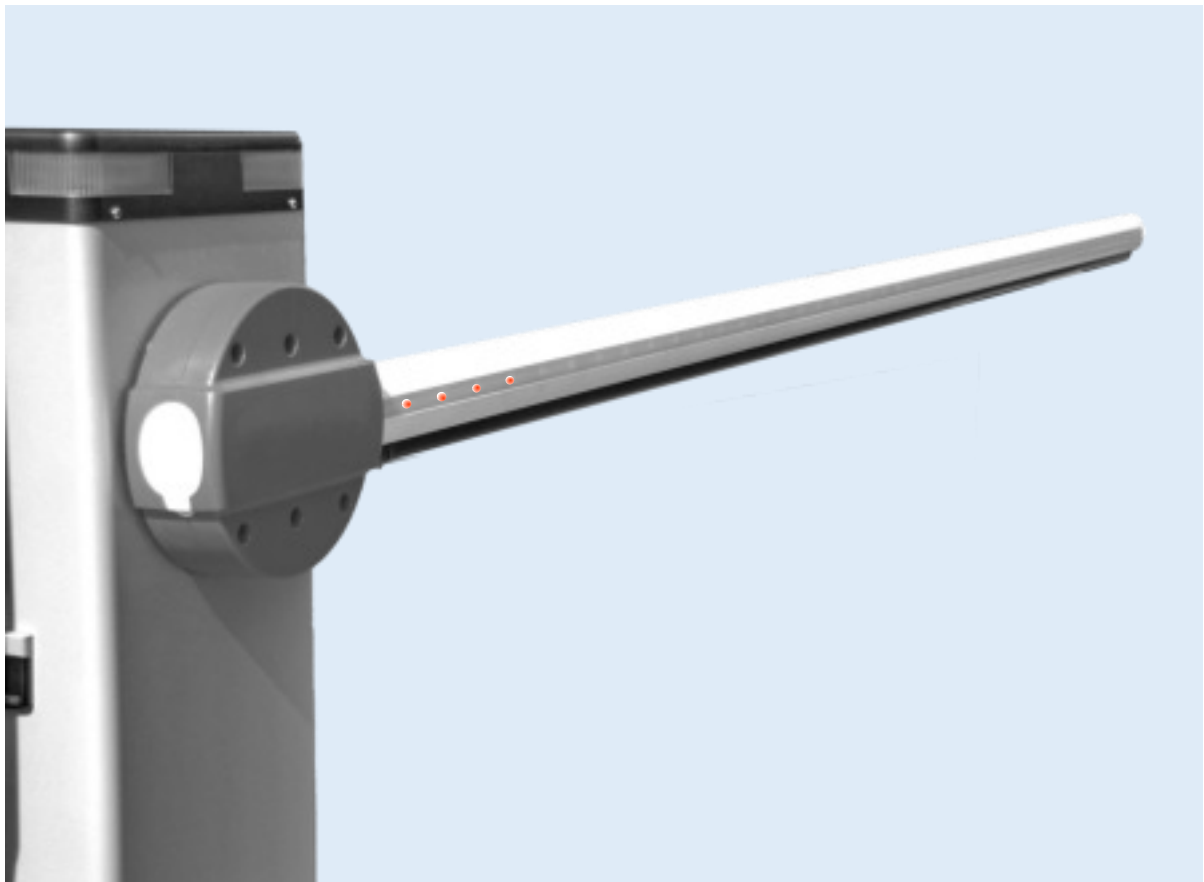

INTRODUCTION TO THE INSTALLATION MANUAL

WARNING! PLEASE READ CAREFULLY

This installation manual contains important warnings and safety instructions for installation. Incorrect installation or incorrect use of the product can cause severe damage to both property and people. Please keep this installation manual for future reference.

1 KEY AND SYMBOLS FOR CONSULTATION

This installation manual is intended solely and exclusively for the technical staff that is professionally qualified and competent to perform the installation task.

This installation and maintenance manual is an integral part of the installed product and must be delivered to the end user for safe storage.

SYMBOLS USED:

 This refers to information that we strongly recommend you read, for your personal safety, for the safety of others and to avoid damage to property.

This refers to warnings on recycling.

 Refers to the voltage grounding

2 USE CONDITIONS

2.1) Intended use

The Agilik automatic barrier has been conceived, designed and produced to be installed for use in private or public car parks, residential, commercial and industrial areas or in areas with a high intensity of passage.

Therefore, this product must and will only be used for the purpose for which it has been designed. Any other use other than that mentioned is prohibited. The manufacturer cannot be held either directly or indirectly responsible for any damage caused by incorrect, improper or unreasonable use.

2.2) Limitations of use

The Agilik series road barrier has been designed for very intensive work cycles; can be installed with a bar length of up to 6 metres, with opening cycles from 2-6 seconds for the version with a bar length of up to 4 metre and 4-8 seconds for the version with the bar length up to 6 metres.

3 GENERAL WARNINGS FOR INSTALLATION AND MAINTENANCE

Carefully read all the information contained in this installation manual, as they contain important information regarding installation, safe use and the related maintenance. Any installation or use other than what is shown in the following installation manual is prohibited.

Warning: The installation, electrical connection, adjustment and maintenance of the automation installed must be carried out by professionally qualified technical personnel. Incorrect installation or incorrect use of the product will cause serious damage to people or property.

RISK ANALYSIS:

 Warning: the installer must analyse the hazards that may occur in the automated closing or the closing to be automated and for each hazard must adopt solutions to permanently remove it.

PRELIMINARY OPERATIONS:

Before connecting the equipment, ensure that the data on the plate correspond to those of the electricity distribution network and that the model conforms to the dimensions and weight of the door.

 Warning: this equipment can exert very high forces that can be a source of hazard.

 Warning: Before performing the installation, carefully check the strength and stiffness of the gate, the pillar, the guides, the mechanical stops in opening and closing, and that manual operation is smooth and regular.

CONNECTING TO THE MAINS

 Warning: Before connecting to the mains, check and perform the following steps:

1) Always provide an upstream differential switch with a threshold of 0.03 A.
2) Provide a suitable double pole switch with a contact gap of at least 3 mm, provided with protection against overloads and short circuits dedicated only to automation.

3) It is mandatory to connect the yellow-green conductor to the terminal marked with the symbol 

 Warning: The safety of this equipment is guaranteed only when it is correctly connected to an efficient grounding system, made according to current safety standards.

 It is necessary to verify this fundamental safety requirement; if in doubt, check the grounding system.

 Warning: connect the metal closing structure to the ground. The manufacturer cannot be held responsible for any damage caused by the system lacking grounding.

 Warning: Do not operate in wet or damp environments without appropriate protection against electric shocks.

 Warning: Before performing any adjustments, maintenance or cleaning, always cut off the power supply.

 Warning: Do not install the device in an explosive environment; the presence of flammable gases or fumes is a serious safety hazard.

 Warning: For maintenance, only use original Roger Technology spare parts.

 Warning: automation must not be put into operation before definitively making all connections, testing the efficiency of the safety devices and setting the thrust force at a minimum.

FINAL CHECKS:

Check the correct operation of the safety devices and the stroke end microswitches; check that the thrust force is within the limits of the standards in force and that the good mechanical safety stops are correctly sealed during opening and closing.

MARKING PLATE:

Clearly indicate in the vicinity of the passage that the equipment is automatic and controlled remotely.

PACKING:

 Open the package by orienting the package with the arrows as indicated on the packing. After removing the packing, make sure of the integrity of the equipment. If in doubt, do not use the equipment and contact a qualified technician.

 Warning: the packaging components (plastic bags, polystyrene foam, nails, cardboard boxes, etc.) must not be left within reach of children as they are potential sources of danger.

Dispose of and recycle the packing components in accordance with the standards in force.

There are no particular risks arising from the automation itself; if possible, recycle the various components separately (aluminium, iron, electrical parts, etc.).

 Warning: the installer must provide the end user with all instructions and warnings of the operation of the automated system and, in particular, the operation of the manual opening operation in the event of emergency.

 Warning: the installer must provide a series of special warnings for the user (see user guide) and, if possible, display them in a convenient place.

MODIFICATIONS

⚠Warning: do not modify or replace parts of the product without written and signed authorization by the manufacturer. Modifications or replacements that are not authorized in writing may cause damage to people, animals and property. Each modification or replacement of parts made and not authorized in writing by the manufacturer is prohibited and release the manufacturer from any direct and indirect liability arising from damages to persons and property.

4 DESCRIPTION OF THE PRODUCT

The Agilik series automatic road barrier is available in 4 standard models, described below; also, it is possible to customize installation with the various standard accessories described in detail in this installation manual.

4.1) Models and characteristics:

AG/001/PE	Agilik brushless 36V DC Barrier for bars up to 3 metres, with on-board control unit, absolute encoder, complete with fixing base with tie rods and screws, and bar fixing flange.
AG/004	Agilik brushless 36V DC Barrier for bars up to 4 metres, with on-board control unit, absolute encoder, complete with fixing base with tie rods and screws, and bar fixing flange.
AG/004/115V	Agilik brushless 36V DC Barrier for bars up to 4 metres, with on-board control unit, absolute encoder, complete with fixing base with tie rods and screws, and bar fixing flange. For line voltages of 115V.
AG/004/IS	Agilik brushless 36V DC Barrier for bars up to 4 metres, with on-board control unit, absolute encoder, complete with fixing base with tie rods and screws, and bar fixing flange. Frame made in Brushed stainless steel AISI 304
AG/006	Agilik brushless 36V DC Barrier for bars up to 6 metres, with on-board control unit, absolute encoder, complete with fixing base with tie rods and screws, and bar fixing flange.
AG/006/115V	Agilik brushless 36V DC Barrier for bars up to 6 metres, with on-board control unit, absolute encoder, complete with fixing base with tie rods and screws, and bar fixing flange. For line voltages of 115V.
AS/006/IS	Agilik brushless 36V DC Barrier for bars up to 6 metres, with on-board control unit, absolute encoder, complete with fixing base with tie rods and screws, and bar fixing flange. Frame made in Brushed stainless steel AISI 304

4.2) Accessories list:

See Fig. 1

- 1) Carbon steel barrier assembly cabinet with anti-corrosion treatment, painted.
- 2) Aluminium bar support base, die-cast, painted.
- 3) Extruded aluminium bar, painted white.
- 4) Galvanized steel omega support for securing the bar.
- 5) Aluminium bar fixing cover, die-cast, painted.
- 6) Aluminium head, die-cast, painted.
- 7) Semi-transparent flashing cover.
- 8) Digital control unit.
- 9) Mechanical stop in opening and closing
- 10) Galvanized steel spring fixing arm.
- 11) Geared motor complete with brushless motor and absolute encoder.
- 12) Key release with DIN cylinder.
- 13) Corrosion-resistant steel closing door, painted.
- 14) AG/BA2/01 elliptical bar up to 2 metres made of aluminium, painted white, with slot cover profiles and shockproof rubber.
- 15) AG/BA3/01 elliptical bar up to 3 metres made of aluminium, painted white, with slot cover profiles and shockproof rubber.
- 16) AG/BA4/01 elliptical bar up to 4 metres made of aluminium, painted white, with slot cover profiles and shockproof rubber.
- 17) AG/BA6/01 elliptical bar up to 6 metres made of aluminium, painted white, with slot cover profiles and shockproof rubber.
- 18) KT230 Galvanised foundation plate for securing the barrier.
- 19) AG/SP72/01 Ø 72 spring for bars of up to 4 metres.
- 20) AG/SP83/01 Ø 83 spring for bars of up to 6 metres.
- 21) AG/BLED Flashing LED 4-board circuit.
- 22) AG/ALED6C - AG/ALED/8C - AG/ALED/12C Strip LED 6 - 8 - 12 metres with connections cable.
- 23) AG/BAMS/01 Mobile support for bars.
- 24) KT231 Fixed support foundation plate.
- 25) AG/BAFS/01 Fixed support with rubber, non-adjustable.
- 26) AG/BAFS/03 Fixed support with rubber, non-adjustable, with provision of a bolt.
- 27) AG/BAFS/02 Fixed support with rubber, adjustable, telescopic.
- 28) AG/BAFS/04 Fixed support with rubber, adjustable, telescopic, with provision of a bolt.
- 29) AG/BAJ/01 Internal connection joint made of anodized aluminium.
- 30) Emergency batteries module (optional).
- 31) Pack of No. 40 reflective adhesive strips for the bar.

5 TECHNICAL CHARACTERISTICS

AG SERIES	AG/001/PE	AG/004	AG/004/115V	AG/006	AG/006/115V
BARRIER	UP TO 3 METRES	UP TO 4 METRES	UP TO 4 METRES	UP TO 6 METRES	UP TO 6 METRES
FREQUENCY OF USE	SUPER INTENSIVE	SUPER INTENSIVE	SUPER INTENSIVE	SUPER INTENSIVE	SUPER INTENSIVE
TRAVEL CONTROL SYSTEM	ABSOLUTE ENCODER DIGITAL	ABSOLUTE ENCODER DIGITAL	ABSOLUTE ENCODER DIGITAL	ABSOLUTE ENCODER DIGITAL	ABSOLUTE ENCODER DIGITAL
POWER SUPPLY	230 V AC - 50 Hz ±10%	230 V AC - 50 Hz ±10%	115 V AC 60 HZ ±10%	230 V AC - 50 Hz ±10%	115 V AC 60 HZ ±10%
MOTOR POWER SUPPLY	FROM 0 TO 36 V DC	FROM 0 TO 36 V DC	FROM 0 TO 36 V DC	FROM 0 TO 36 V DC	FROM 0 TO 36 V DC
POWER CONSUMPTION	FROM 0 TO 15 A	FROM 0 TO 15 A	FROM 0 TO 15 A	FROM 0 TO 15 A	FROM 0 TO 15 A
POWER MOTOR	450 W	200 W	200 W	200 W	200 W
TORQUE	FROM 0 TO 200 Nm	FROM 0 TO 200 Nm	FROM 0 TO 200 Nm	FROM 0 TO 200 Nm	FROM 0 TO 200 Nm
OPEN / CLOSE TIME 90 °	FROM 2 TO 4 seconds	FROM 2 TO 6 seconds	FROM 2 TO 6 seconds	FROM 4 TO 8 seconds	FROM 4 TO 8 seconds
OPERATING TEMPERATURE	-20 +55 °C	-20 +55 °C	-20 +55 °C	-20 +55 °C	-20 +55 °C
ACCESSORIES POWER SUPPLY	24 V DC	24 V DC	24 V DC	24 V DC	24 V DC
CONTROL UNIT (INTEGRATED)	DIGITAL CONTROLLER 36V DC	DIGITAL CONTROLLER 36V DC	DIGITAL CONTROLLER 36V DC	DIGITAL CONTROLLER 36V DC	DIGITAL CONTROLLER 36V DC
RELEASE SYSTEM	KEY WITH DIN CYLINDER	KEY WITH DIN CYLINDER	KEY WITH DIN CYLINDER	KEY WITH DIN CYLINDER	KEY WITH DIN CYLINDER
PROTECTION RATING	IP 54	IP 54	IP 54	IP 54	IP 54
EMERGENCY BATTERY	AVAILABLE (OPTIONAL)	AVAILABLE (OPTIONAL)	AVAILABLE (OPTIONAL)	AVAILABLE (OPTIONAL)	AVAILABLE (OPTIONAL)
OPERATING CYCLES PER DAY (OPENING/CLOSING - 24 HOURS NO STOP)	n° 8000	n° 5000	n° 5000	n° 4000	n° 4000

1

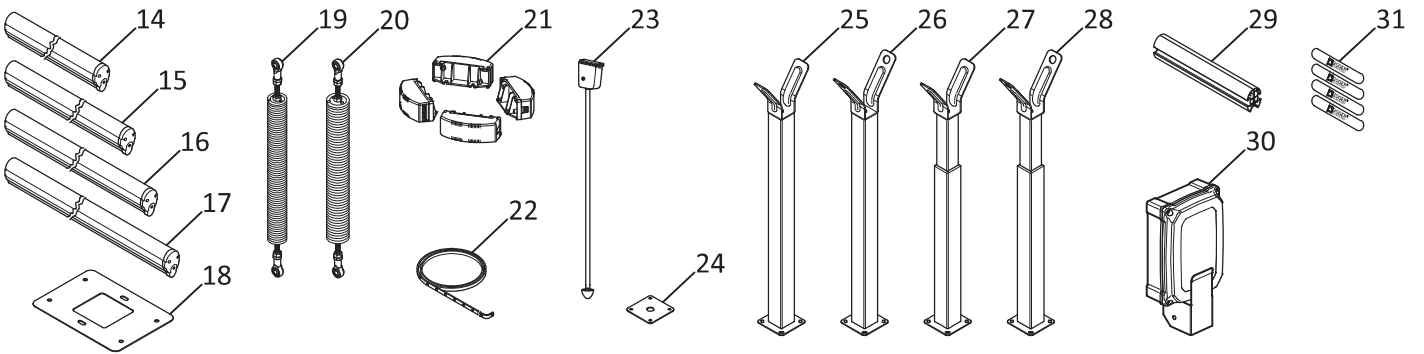
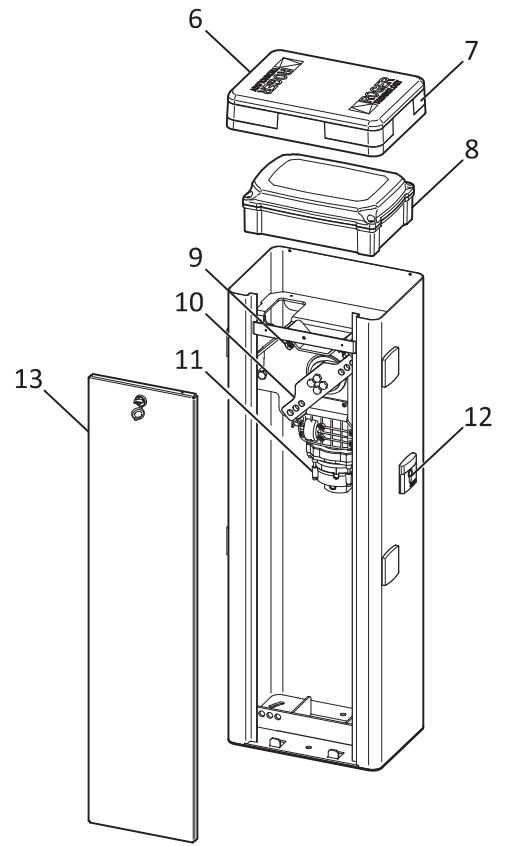
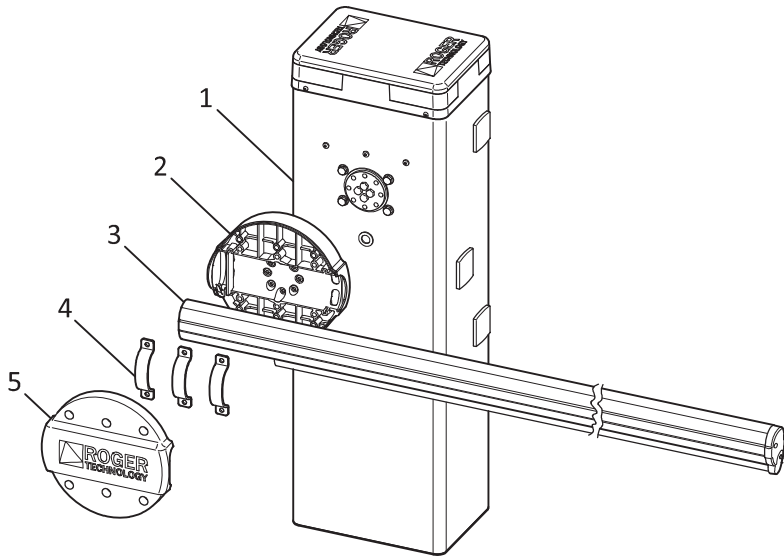

6 STANDARD DIMENSIONS

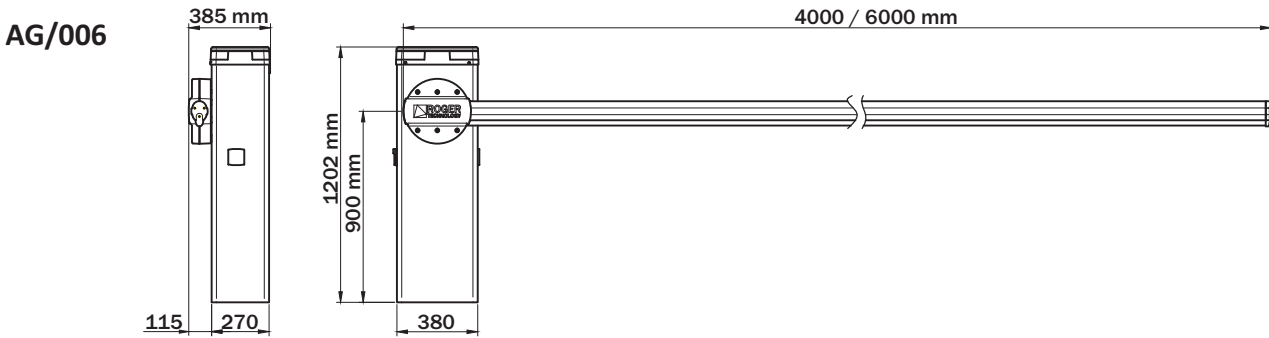
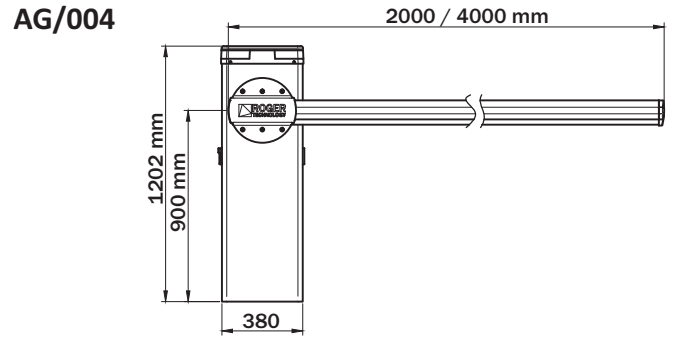
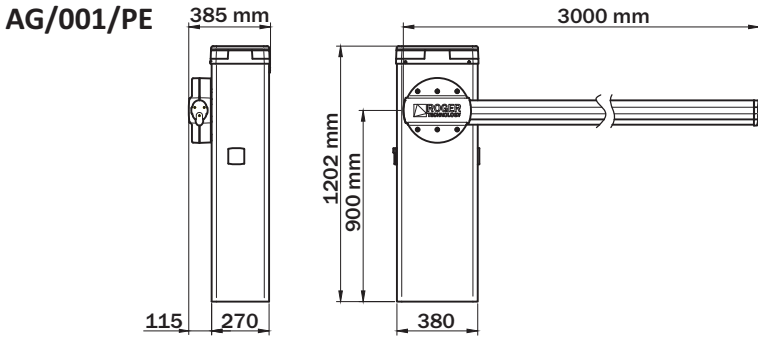

The installation must be performed by qualified and experienced personnel, in full compliance with the regulations.

For General instructions for installation and maintenance, refer to section 3 of this installation manual.

7.1) Preparation and installation of the foundation plate

The following illustrations are for illustrative purposes only, as the space for securing the automation and the accessories varies depending on the dimensions. It is therefore the installer who selects the most suitable solution for analysing the spaces and the surrounding environment, ensure that there are no impediments to the movement of the bar, such as trees, electricity cables, street lights or other things and carefully selecting the most suitable automation for installation to be carried out, based on the width of the passage and the limits of use.

Assemble the 4 anchors complete with nuts; warning: the lower nut must be screwed to the end of the thread, so as to comply with the "Z" minimum height of 40 mm as shown in Fig.2. Run the foundation hole with the following minimum dimensions: one metre by one metre and a depth of 0.3 metres, to accommodate the "KT230" foundation plate, as shown in Fig 3. Position the conduit for the passage of the electric cables.

Perform an adequately reinforced concrete cast with iron cages, flood the central foundation plate so it is flush with the surface, perfectly level and parallel to the structure of the barrier and the bar, which is to be installed later, after the concrete is completely set, as shown in Fig. 3.

The concrete foundation must be made following the standard rules, by competent personnel.

7.2) Installing the barrier assembly

After successfully laying the foundation plate (7.1), install the body of the barrier.

Remove the washers and nuts screwed onto the tie rods on the "KT230" foundation plate that was previously cemented, as shown in Fig 4.

Unscrew the 2 screws fixed on the head of the case, on the side where the bar is to be fixed, as shown in Fig 5.

Open the inspection door through the appropriate lock by turning the key 90° clockwise, as shown in Fig. 6.

Manually lift the head, disconnect the grounding cable dedicated to the head from the concentrator; support the head on a suitable surface so as to avoid impacts or electrical damage.

After also disconnecting the grounding cable dedicated to the inspection door from the concentrator (Fig. 7), it is possible to open the door by removing it from its slot.

Support the case on top of the "KT230" foundation plate so that the cemented tie rods pass through the 4 slotted holes located in the 4 corners of the base.

Insert the washers and nuts that were removed onto the tie bars, as shown in Fig. 8; orient the case as desired, using the slots of the base and then tighten the nuts firmly for the barrier body case in a stable manner.

Important Note:

In terms of electronics, the barrier is set in the factory for installation on the right (DX), when looking at the gate from the inside. In the event that installation is to be done on the left (SX) follow the instructions given in the bar assembly section.

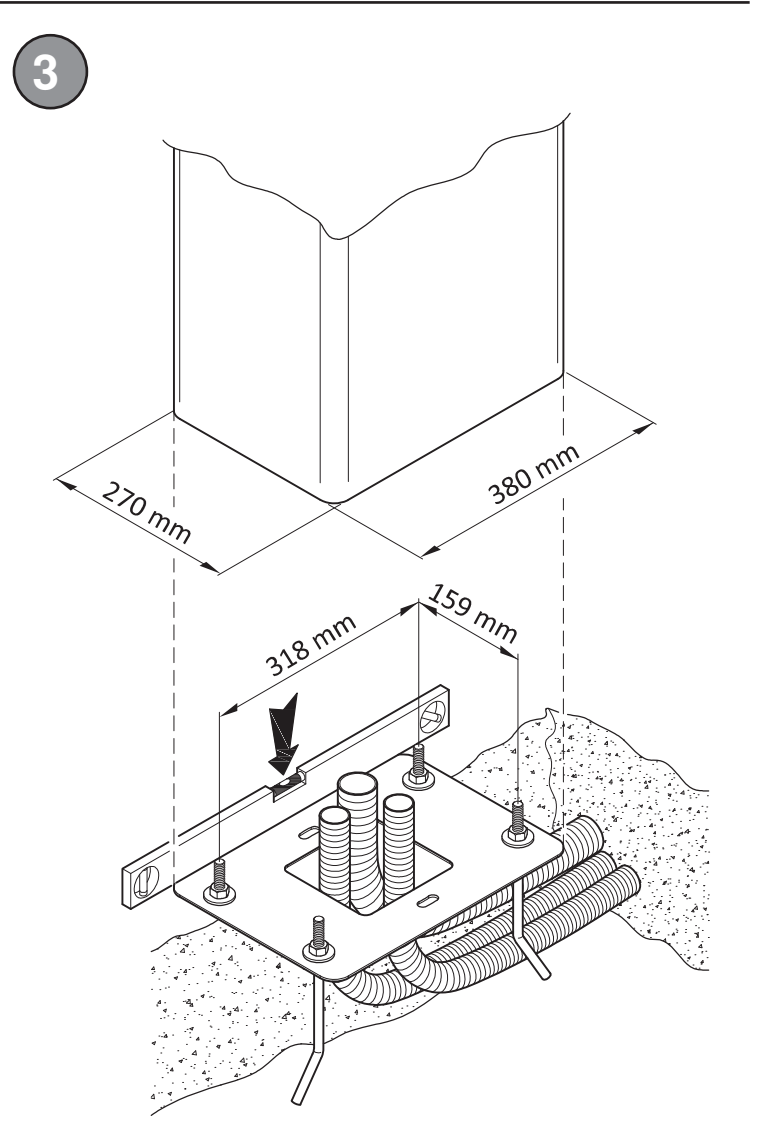
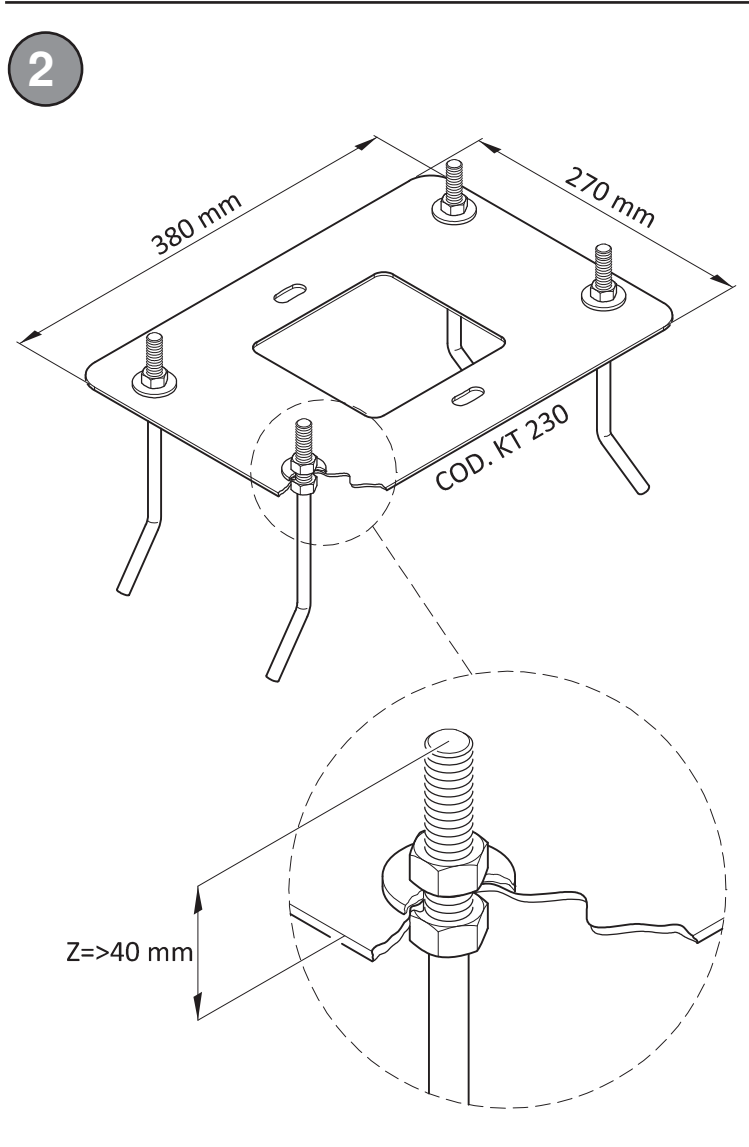

4

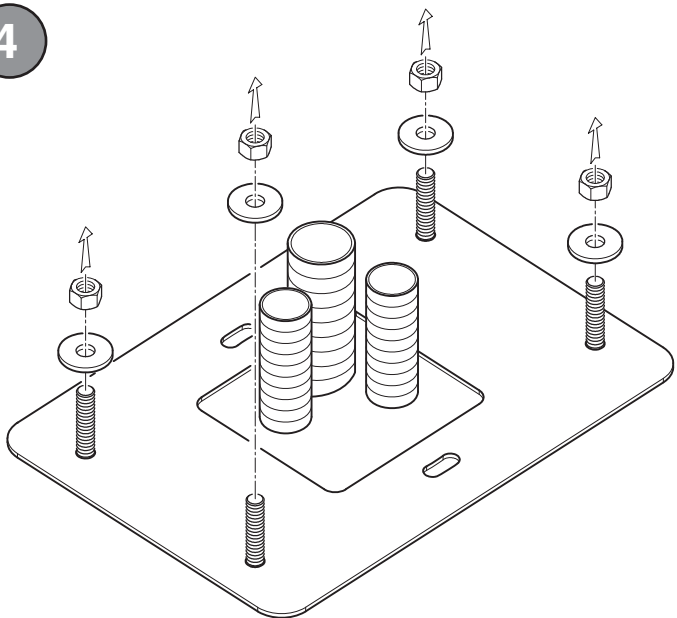

5

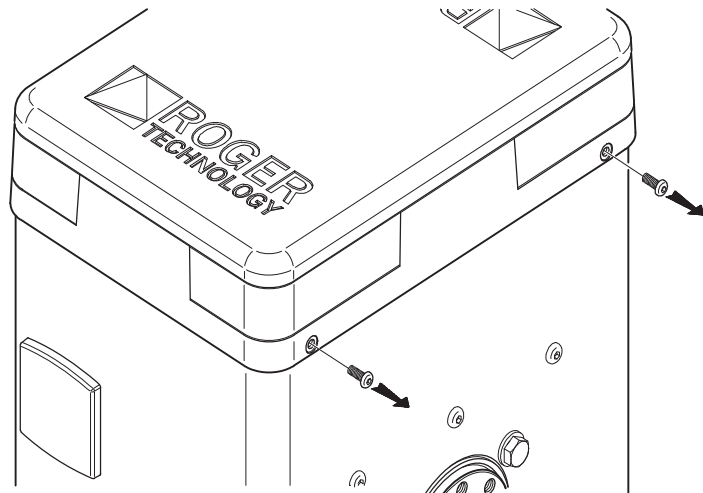

6

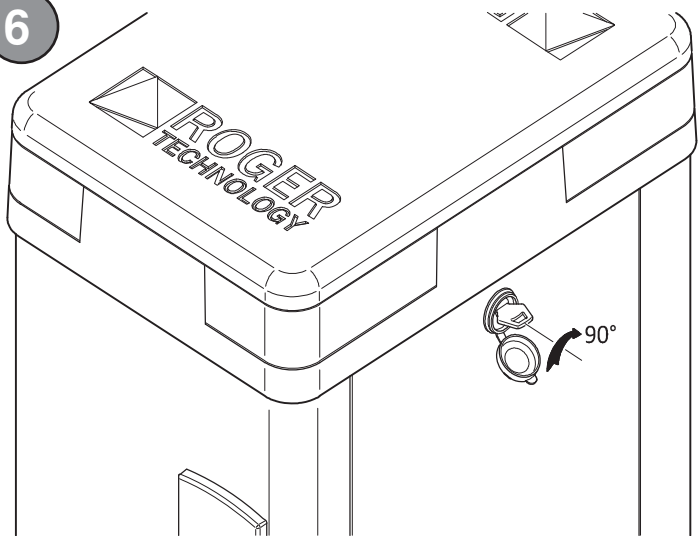

7

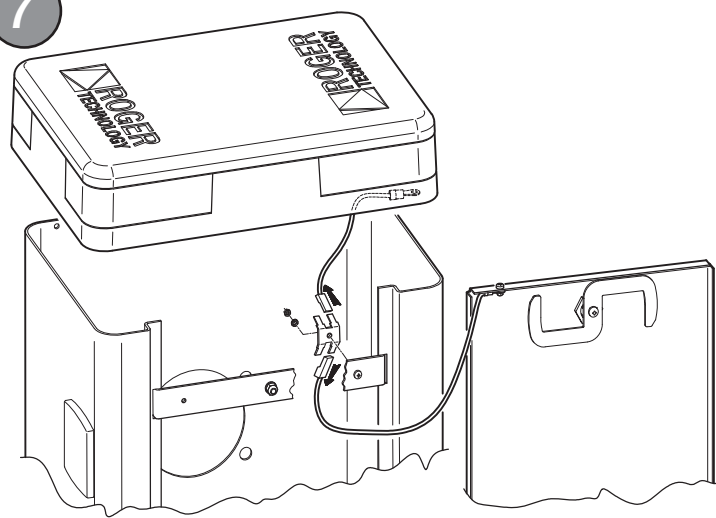

8

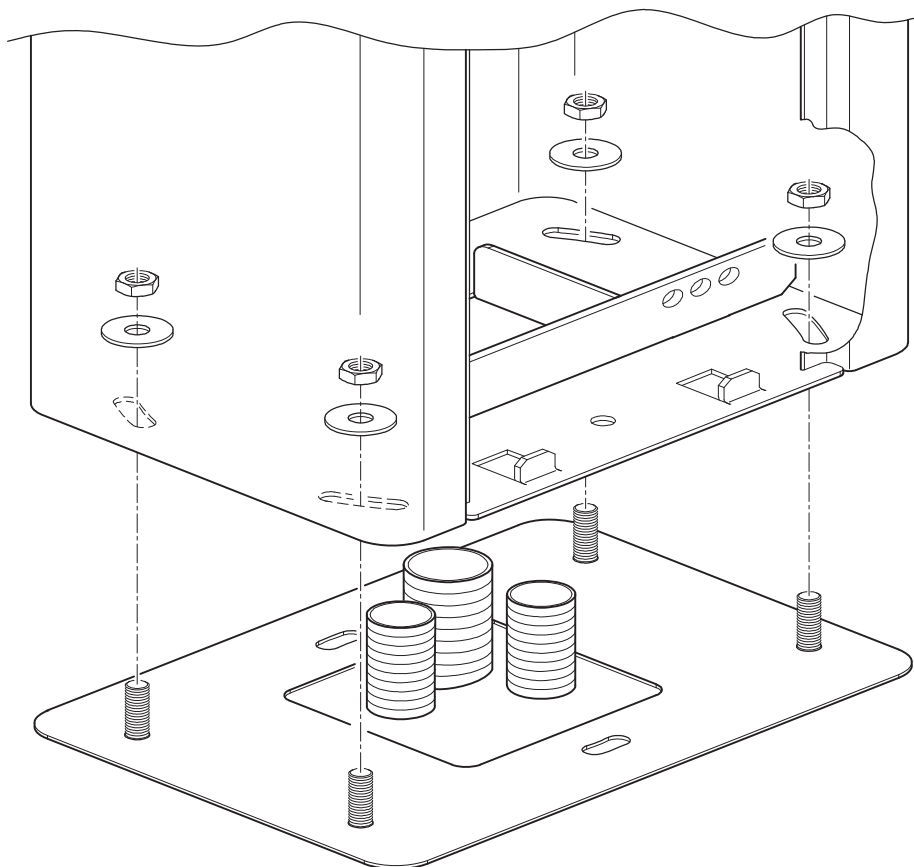

7.3) Installation of the bar

Before installing the bar, ensure that the internal arm for securing the spring is oriented in the correct direction, according to the arrangement of the barrier of a right or left installation, as shown in **Fig 9**.

To install a bar, proceed as described:

Release the geared motor through the appropriate release key supplied with the barrier (see Chapter 10); manually rotate the arm until it reaches the proper recommended position, which provides for the ability to vertically insert the bar, using a removable iron support such as a bar support point, when inserted

(Ref. "E" **Fig. 10**). Tighten the geared motor again by turning the key in the opposite direction and proceed with the assembly of the bar as shown in **Fig 10**: Secure the aluminium bar support base (**A**) with 8 galvanized M10 screws (**B**) to the fixing flange that comes out of the geared motor (**C**). Tighten with adequate strength.

Rest the bar (**D**) in its slot and push it in support to the steel plate (**E**); apply the three moulded steel flanges (**G**) and secure with 6 galvanized M10 screws (**B**). Tighten with adequate strength. Position the plastic end cap in its slot (**F**). Now apply the final aluminium cover (**H**) and secure it with 6 steel M10 screws (**K**). If necessary, reverse the orientation as follows:

Release the geared motor (see Chapter 10); manually rotate the arm until it reaches the proper key in the opposite direction. Tighten the geared motor by turning the key in the opposite direction.

Now remove the cover of (H), loosen the fixing flange until the bar slides freely, (G), remove the plastic end cap (F) and slide the bar up to the desired position.

Position the plastic cap and reattach all previously removed or loosened parts.

Note: For correct configuration of the left/right opening of the automatic barrier, refer to the of the control unit manual AG / CTRL parameter No. 71.

9

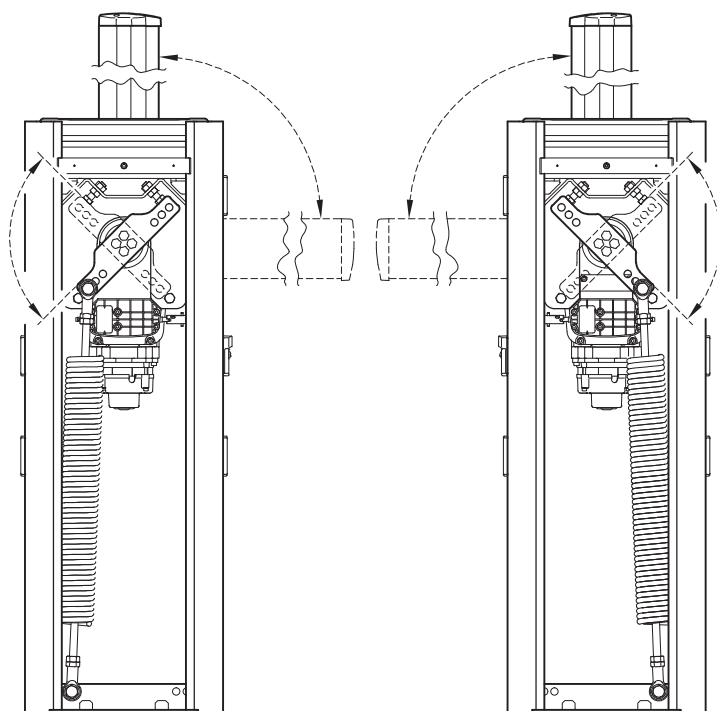

10

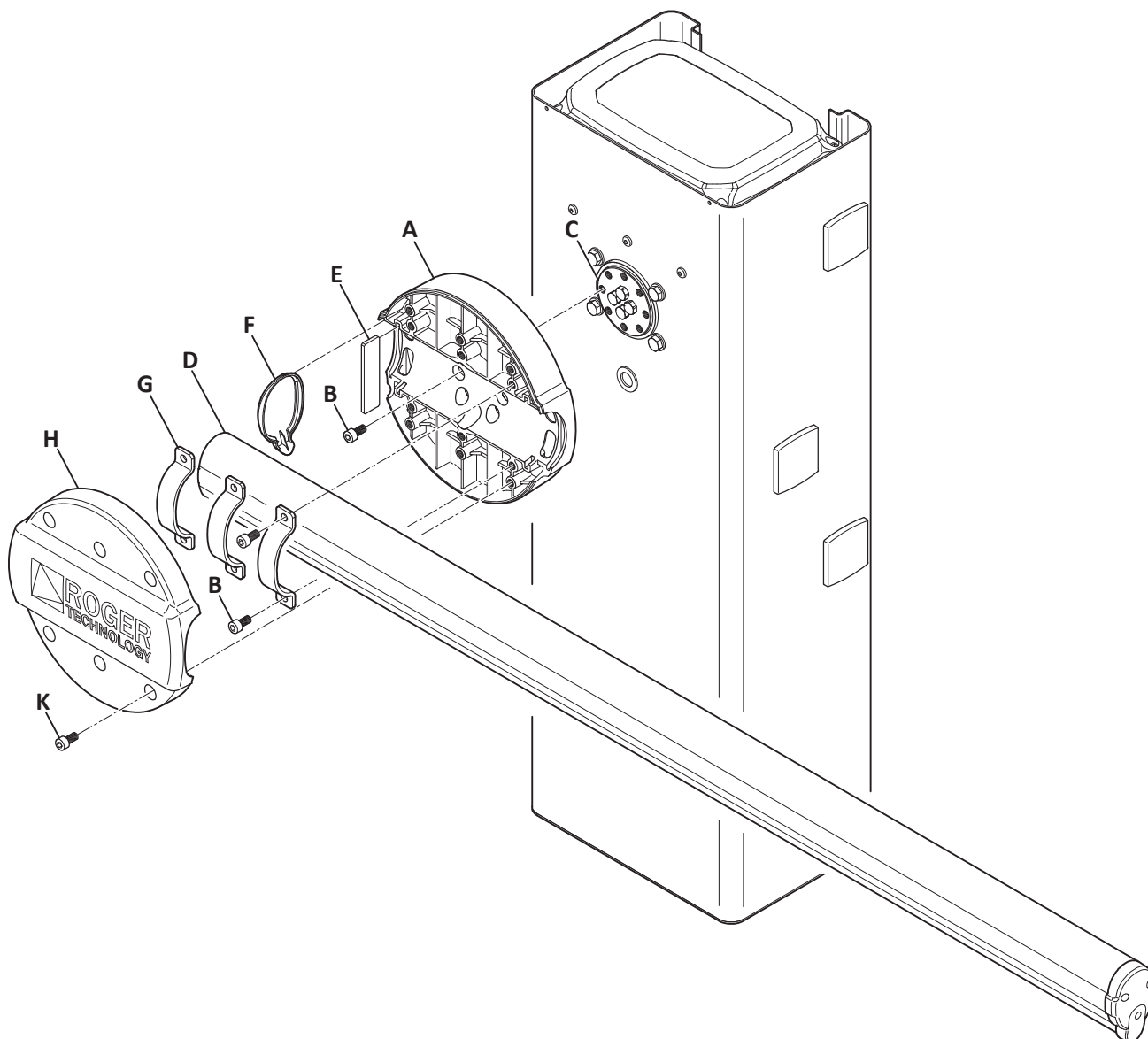

8 BAR BALANCING SPRING

8.1) Installation and balancing of the spring of the bar

To balance the forces in play and for proper operation of the automatic barrier, it is necessary to install a balancing spring.

Depending on the length of the bar that you intend to install, choose between two different models of the following springs:

AG/SP/72: Spring for bars of **up to 4 metres**.

AG/SP/83: Spring for bars **up to 6 metres** in either a single bar or 2 joined bars.

To assemble the spring, choose a pair of holes from the steel supports highlighted in **Fig 11** (e.g. **A-1, A-2** or **B-2** etc.), paying attention to assemble the spring on the right side, based on the position of the bar. Warning: using holes positioned closer or further away from the centre of the arm affects the tension of the spring, for example, if you use hole No. 3, the spring is more stretched.

Secure the spring by screwing it into steel arm, in the arranged holes, using the supplied screws, following the diagram in **Fig. 12**.

Secure the spring to the fixed structure, on the steel beam at the base of the column of the barrier using the supplied screws, following the diagram in **Fig. 13**.

Note that both springs are indicated with a red or yellow colour in the respective hubs, according to the diameter type of the spring. So pay attention during the installation, ensuring that the coloured part of the spring is always positioned upward.

8.2) Adjusting the spring tension

When the automation is released (see Chapter 10), manually move the bar by 45° and release it. If it opens or closes, it means that the balance is not optimally set. This depends on the length of the bar and the accessories installed in it and therefore on its own weight.

For optimum results, it is necessary to adjust the tension of the previously installed spring, initially by unscrewing the lock nuts of the spring, shown in **Fig. 14**, both the one above and the one below and manually rotate the spring (**Fig. 15 A**) in a clockwise or anticlockwise direction to decrease or increase the tension; when the adjustment of the tension of the spring is optimal, it is necessary to firmly tighten the locking nuts of the spring (**Fig. 15 B**).

11

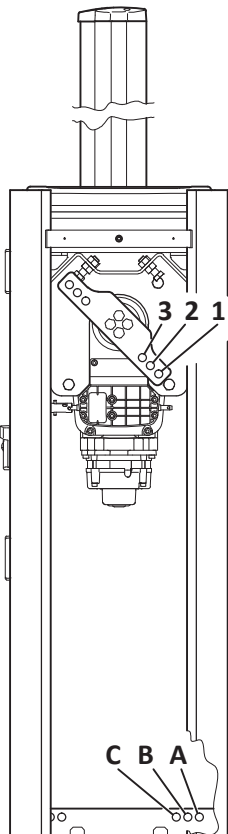

12

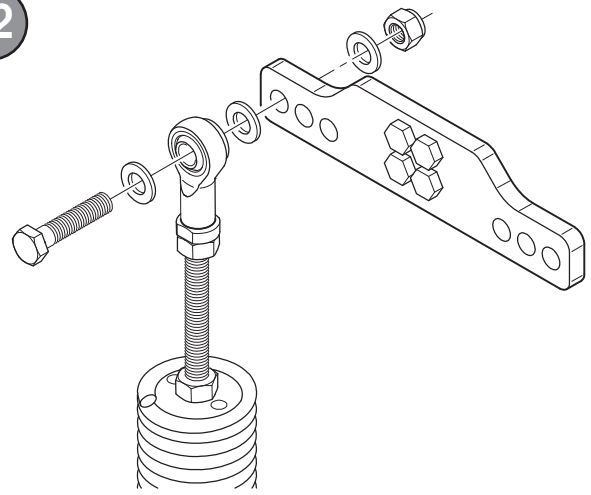

13

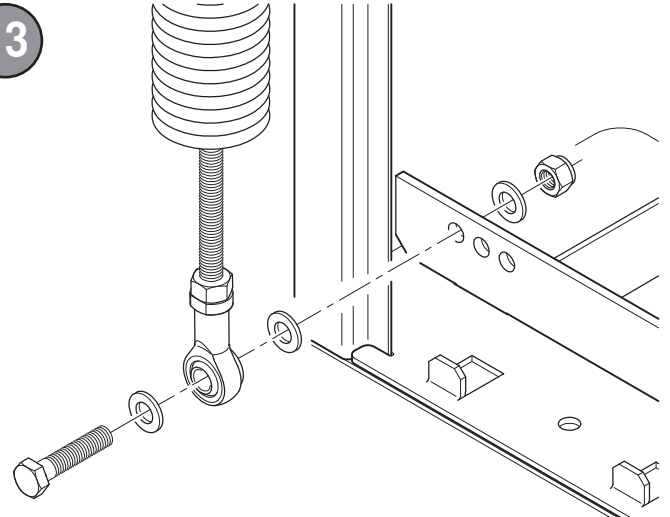

14

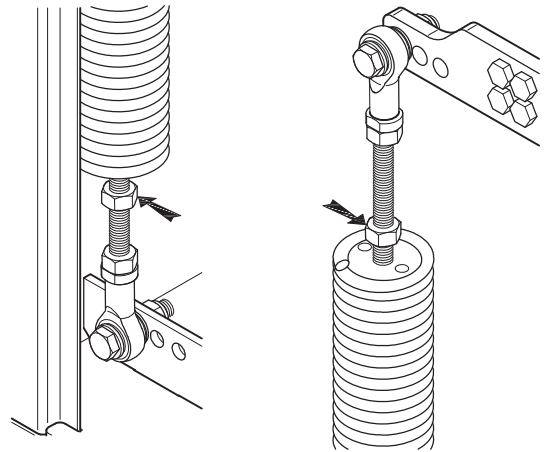

15

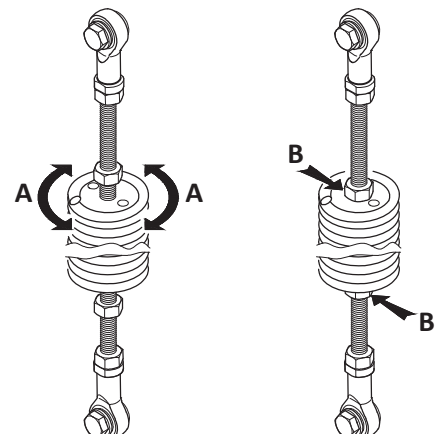

9 ADJUSTING THE MECHANICAL STOP IN OPENING AND CLOSING

The automation is provided with mechanical stops in opening and closing which must be adjusted with precision, following the procedure indicated below.

Warning: **Fig. 16** shows the installation of a **LEFT** automation; in the event of a **RIGHT** installation, it is necessary to adjust in a specular fashion.

Unlock the automatism with the supplied key (see Chapter No. 10).

Adjust the screws of the mechanical stop in closing (**Fig. 16** point **A**) to horizontally adjust the bar in a closed position. Adjust the screws of the mechanical stop in opening (**Fig. 16** point **B**) to vertically adjust the bar in an open position.

10 AUTOMATISM RELEASE

In some situations, such as in the event of a power outage or scheduled or extraordinary maintenance, it is necessary to release the automation.

The operation of the release of the automation must never be carried out when the bar is in motion and it is therefore necessary to ensure that the bar is stopped and in the closed position (horizontal).

Moreover, ensure that at the time of release, no person, animal, item or vehicle is passing by or stopped within range of automation.

To release it, it is necessary to insert the release key supplied on the lock, which is located on a side of the case (**Fig. 17**), and make 2 complete turns anticlockwise ($2 \times 360^\circ$).

To lock the automatism again, it is necessary to turn the key clockwise and make 2 full turns ($2 \times 360^\circ$).

In the case of incorrect installation or improper securing of the bar in its slot during assembly, or in the case of a bar that has been broken by an accident or another cause, the springs installed under tension no longer guarantee the balancing set. Pay attention as this situation can cause sudden rotation of the bar, during the release operation, and therefore pose a potential hazard to the user.

10.1 Assembly of the release system on the opposite side

The release system is assembled in the factory on one of the two sides of the case. It is possible to disassemble and reassemble it on the opposite side, by following the procedure shown in **Fig 18**:

Open the inspection door of the automation case.

Unscrew the fixing screws of the plastic cover (**A**) on the side on which you want to install the release.

Remove the plastic cover plate (**B**) of the release system, by leveraging the four side latches; unscrew the two self-tapping screws (**C**) and remove the aluminium front (**D**); remove the four M5 nuts (**E**).

Now the release system is no longer secured to the automation structure and so release is possible, by pushing the steel joint outwards (**F**) by compressing the spring, and then rotating the same joint by 45° (**G**), finding the self-retaining point.

In order to assist and to check the correct assembly of the release, on the opposite side two **RED** and **GREEN** caps have been included in the rotation plugs.

Note: To check the correct assembly of the release independently of the side, check that the two green plugs are facing the operator's side if the barrier is blocked. In the case where the green caps are facing the opposite side of the operator, this means that the release has been assembled otherwise.

Then, remove the release box and assemble it on the opposite side, paying attention to the safety wiring.

For the final fixing, follow the instructions in reverse. Lastly, complete the task by fixing the plastic cover (**A**) on the side where the release was initially assembled.

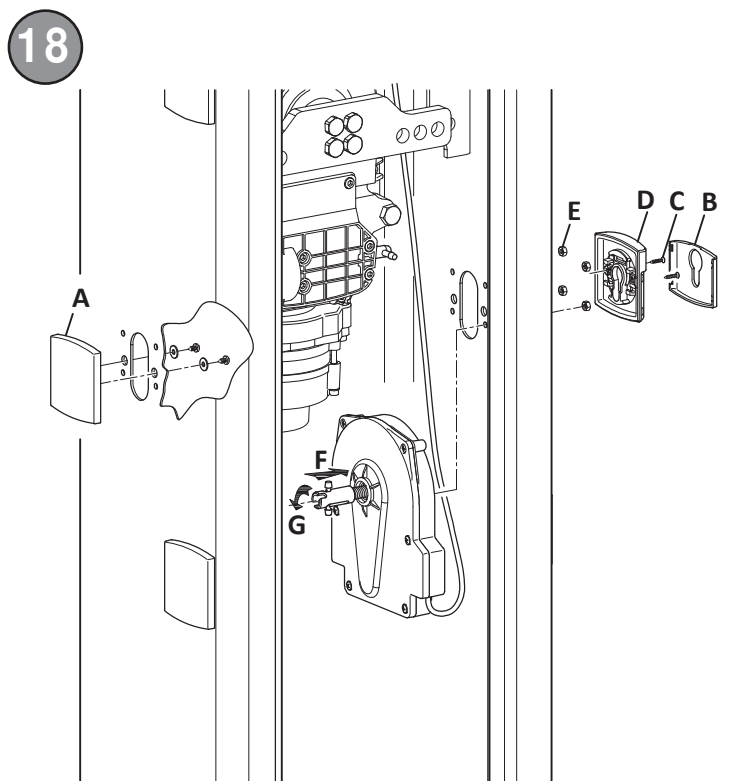
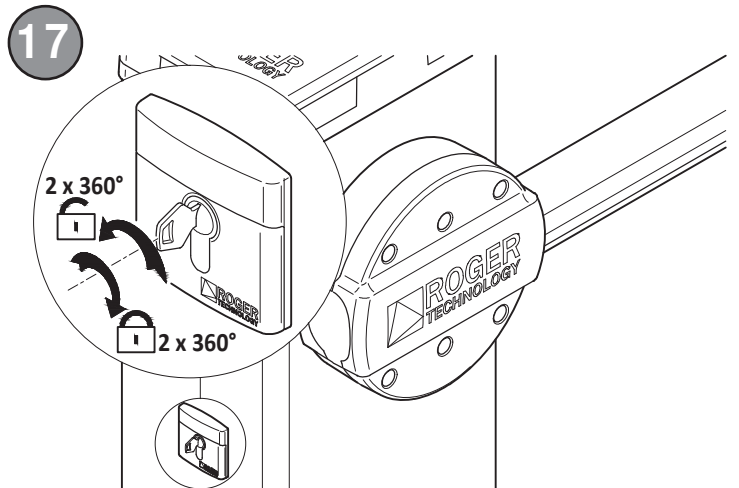
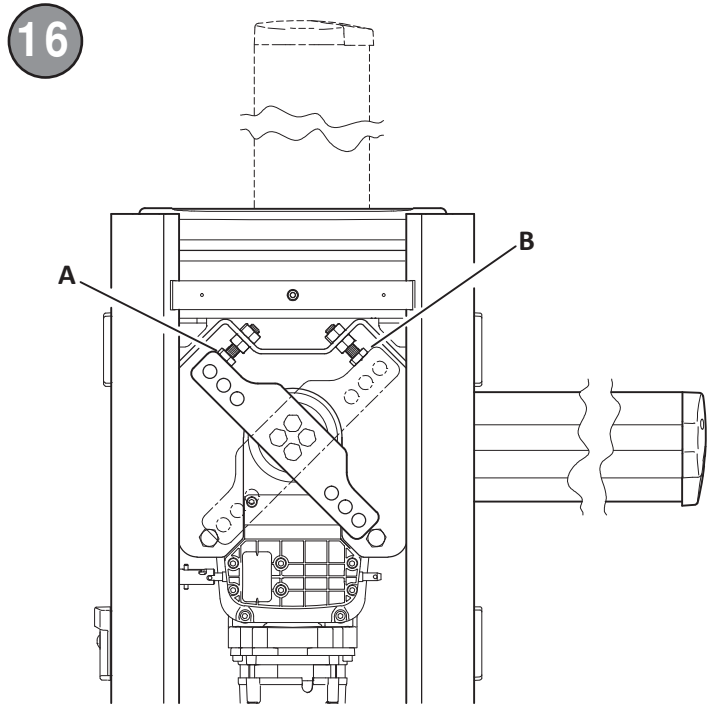

11 INSTALLING THE FLASHING LED CIRCUIT OF THE BARRIER ASSEMBLY HEAD (AG / BLED)

To install the 4-quadrant flashing LED on the head of the barrier assembly, proceed as follows and what is shown in **Figure 19**.

- Cut off the power from the automation, insert the key and release the inspection door sealing hook attached to automation cover.
- Remove the 2 fixing screws of the head of the barrier and remove it completely, paying attention to the ground wire, which must be disconnected.
- By overturning the complete head we can see the slots where the 4-quadrant LED circuit should be installed, which must be correctly positioned in their slots, using the 2 fixing screws for each quadrant supplied, avoiding passing the cables between the quadrants on the side where the slot of the latch of the inspection door is located. See point "X".
- The final part of the 4-quadrant LED circuit is inclusive of the connection plug. The wiring is also provided, which must be connected directly to the control unit. To make this connection, pass the connecting cable with the connection plug to the unit box under the box through the cable hole and connect it correctly to the unit in the hall dedicated input. Finally, connect the two connection plugs to each other.
- Provide power and enter into the programming of the unit **AG/CTRL** and in in extended mode, position yourself in parameter No. 78 and configure the desired flash mode.
- Tightly and correctly close the cover of the box of the unit, reposition the aluminium cover of the barrier assembly in the correct direction, close and attach the inspection door and fix the two final screws of the cover of the aluminium head.

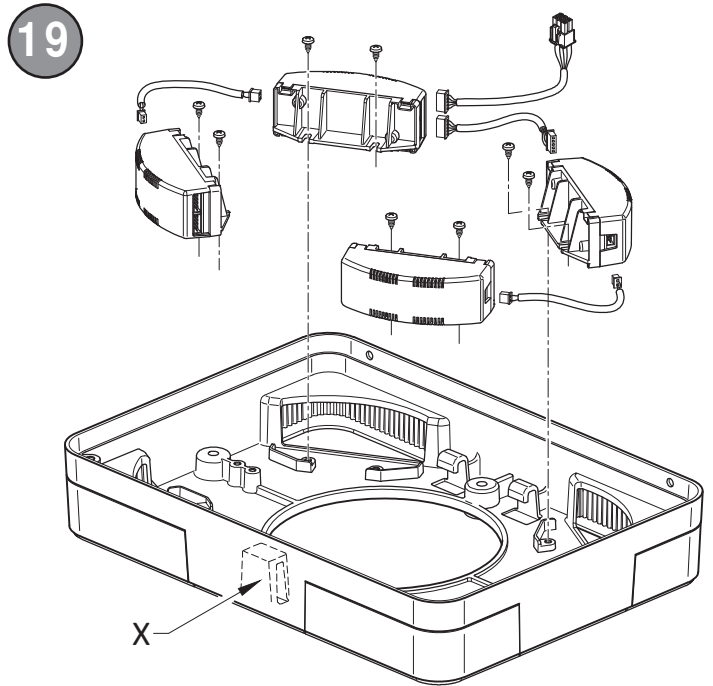

12 CONNECTING THE PHOTOCELLS IN THE BARRIER ASSEMBLY

On both sides of the barrier body, it is possible to install the photocells of the **G90** series and largely the **G90/F4ES** photocells Pair of photocells for external sync.

In both sides, the photocells can be installed at two heights of 50 cm or 100 cm from the bottom of the column, see **Figure 20**.

To install the photocell, cut off the power from the barrier, remove the cover of the head and open the inspection door.

Position yourself over the desired photocell, loosen the two screws that hold the plastic cover from the inside of the barrier body, fasten the photocells to the side of the barrier cables by passing the cables upwards, avoiding the wiring in a way that disturbs the movement of the automation. Use the cable gland, located under the box containing the control unit and connect it to the unit into the dedicated input.

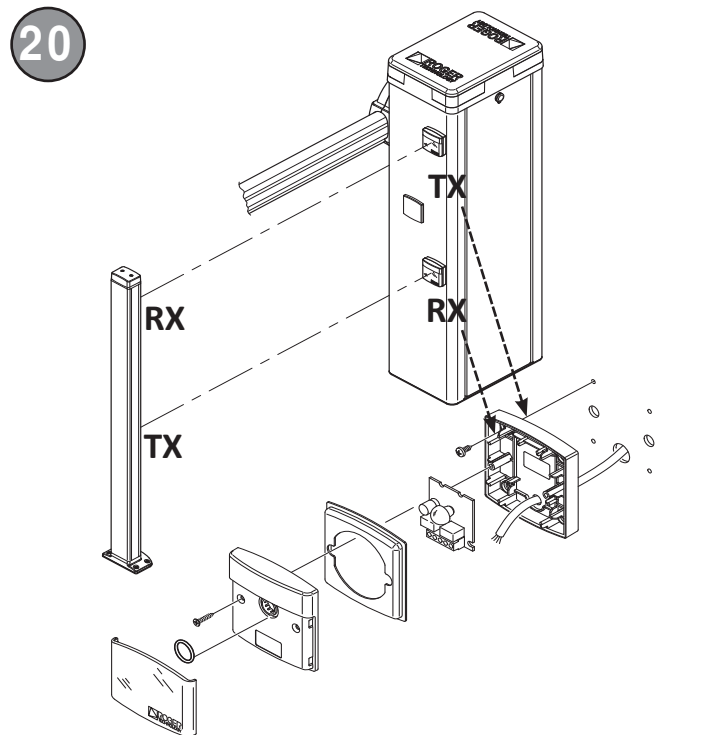

13 INSTALLATION AND CONNECTION OF THE EMERGENCY BATTERIES MODULE

The battery module **B71/BCHP** should be connected and installed inside the cabinet, it should be carried out as shown in **Fig. 21**.

The galvanized steel support of the battery holder box must be inserting in one of the two side niches on the right or left. Please note that it should be assembled on the opposite side of the balance spring.

To electrically connect the battery to the unit, consult the instructions manual of the installed battery module.

Ensure the battery's power cable so that it does not suffer damage during the movement of the mechanical parts inside the cabinet.

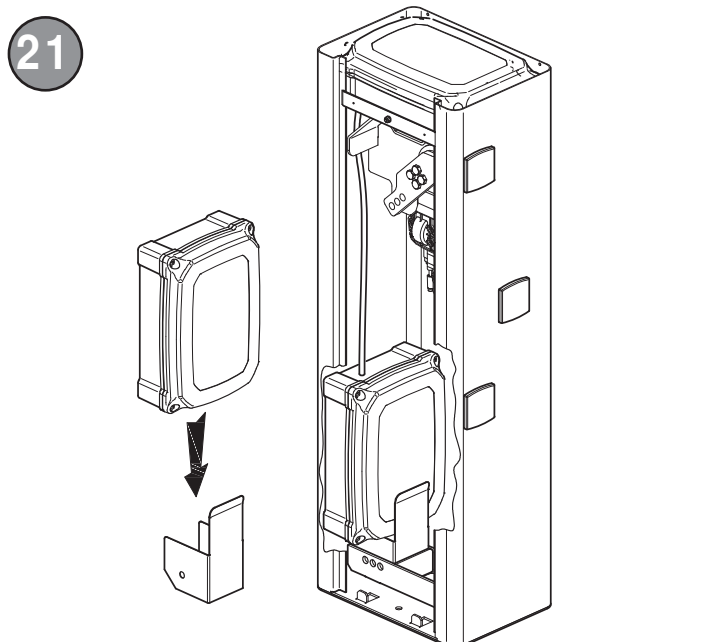

14 CONNECTING AND PROGRAMMING THE CONTROL UNIT

For connections and programming of the electronic control unit, refer to the instruction manual of the installed control unit, **AG/CTRL** supplied inside the automatic barrier, together with the installation manual in question.

The automation is designed to be powered by the mains supply at 230V AC 50 Hz.

Therefore, connect the automation to the mains through a double insulated 3x2.5 mm² cable, making it pass through a submerged pipe prepared during the installation of the KT230 foundation plate (see Fig.3).

Once inside the cabinet, the cable must continue upward on the left side of the automation; insert it through the rubber cable gland to the left of the box and connect it to the terminal block with a fuse, as shown in Fig. 22.

Ensure the cable so that it does not suffer damage during the movement of the mechanical parts inside the cabinet.

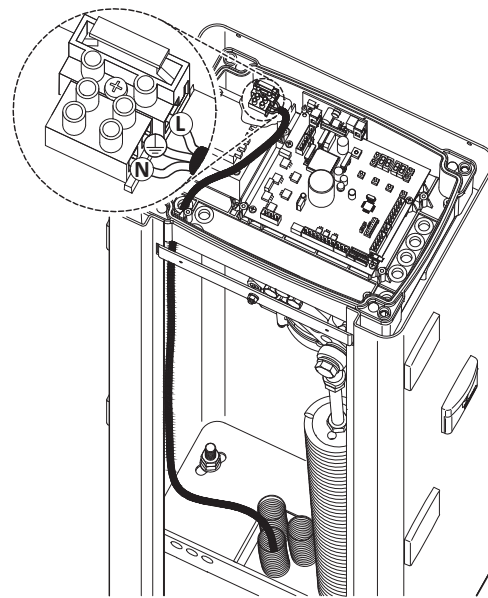

15.1) Type of connection cables and minimum thicknesses

CONNECTION	CABLE TYPE	CABLE LENGTH 1 - 10 m	CABLE LENGTH 10 - 20 m	CABLE LENGTH 20 - 30 m
230V Power supply	OUTDOOR CABLES FOR UNDERGROUND INSTALLATION CEI EN 50267-2-1	3 x 2.5 mm ²	3 x 2.5 mm ²	3 x 4 mm ²
Photocell transmitters		2 x 0.5 mm ²	2 x 0.5 mm ²	2 x 0.5 mm ²
Photocell receivers		4 x 0.5 mm ²	4 x 0.5 mm ²	4 x 0.5 mm ²
24V accessory power		2 x 0.5 mm ²	2 x 0.5 mm ²	2 x 1 mm ²
Safety and control devices		2 x 0.5 mm ²	2 x 0.5 mm ²	2 x 0.5 mm ²
Antenna Connection	RG58	MAX 10 m		

16 INSTALLATION OF A SYSTEM TYPE

Here we list the components needed for installation of a system type of an Agilik 4 or Agilik 6 series automation.

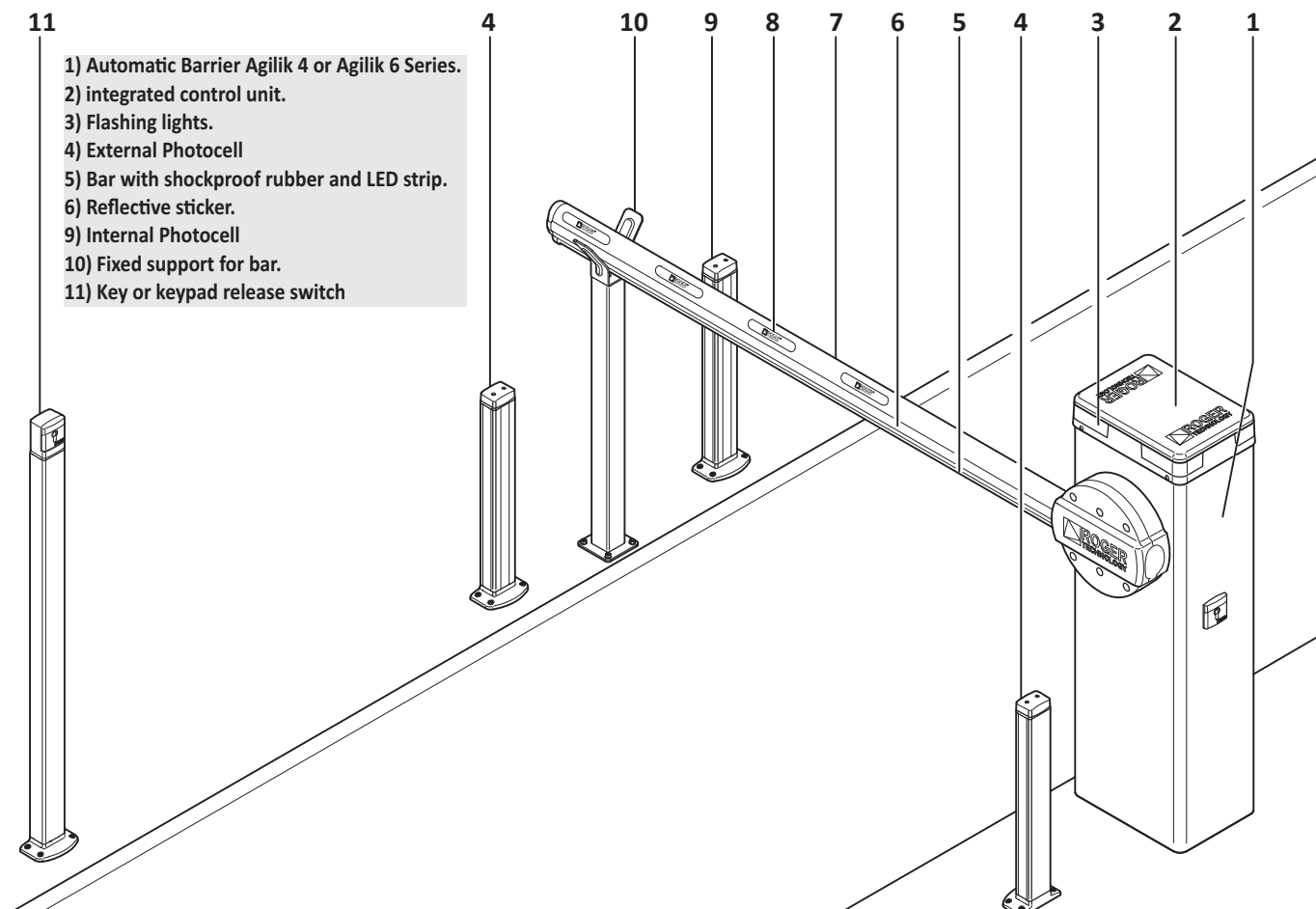

- 1) Automatic Barrier Agilik 4 or Agilik 6 Series.
- 2) integrated control unit.
- 3) Flashing lights.
- 4) External Photocell
- 5) Bar with shockproof rubber and LED strip.
- 6) Reflective sticker.
- 9) Internal Photocell
- 10) Fixed support for bar.
- 11) Key or keypad release switch

17.2 Unscheduled maintenance

The following table is made available in order to record all extraordinary maintenance, repair and improvement interventions carried out by qualified external companies, only using specialized technicians.

Date of intervention		Stamp of the installer
Company		
Operator name		
Intervention performed		
Problems encountered		
Improvements made		

Date of intervention		Stamp of the installer
Company		
Operator name		
Intervention performed		
Problems encountered		
Improvements made		

Date of intervention		Stamp of the installer
Company		
Operator name		
Intervention performed		
Problems encountered		
Improvements made		

Date of intervention		Stamp of the installer
Company		
Operator name		
Intervention performed		
Problems encountered		
Improvements made		