



Vehicle Access Control
Pedestrian Access Control
Safety & Security Equipment

T: +61 7 3205 1123

www.rotech.com.au

e: info@rotech.com.au

(V0518)

SENTINEL PL SERIES BOOM GATE CW Spikes Installation Instructions



SENTINEL PL BOOM GATE

BOOM GATE SIZES

3.0 Metre 4.5 Metre 6.0 Metre

CABINETS

2 mm Zincanneal steel,
2nd Coat with zinc primer,
Final colour coat white UV stable powder.
(Also available in 2 mm stainless steel, etch primed and powder coated.)

COLOURS

The standard colour is a white cabinet with a white cover.
Other colours are available on request.

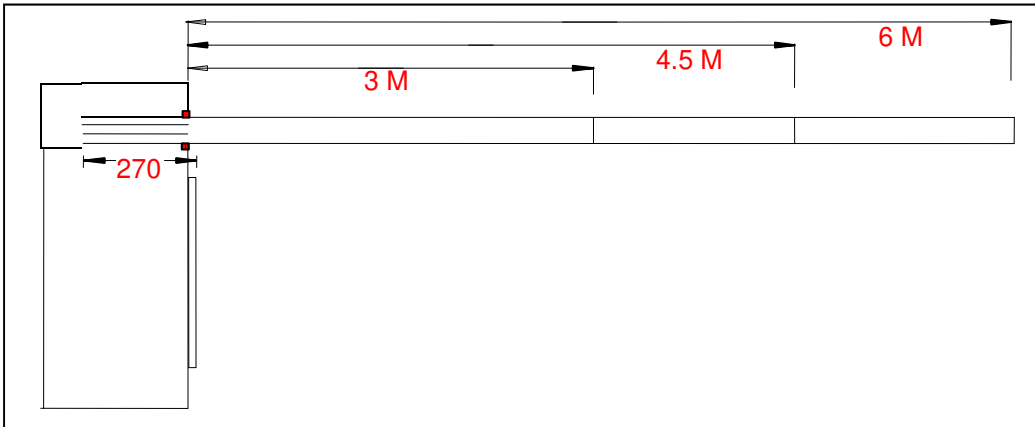

MOTOR

All PL Series Boom Gates are fitted with a 240 VAC single phase, 60 watt torque motor. The 3 and 4.5 metre boom gates are fitted with a 10 rpm motor and the 6 metre with a 5.5 rpm

HANDING

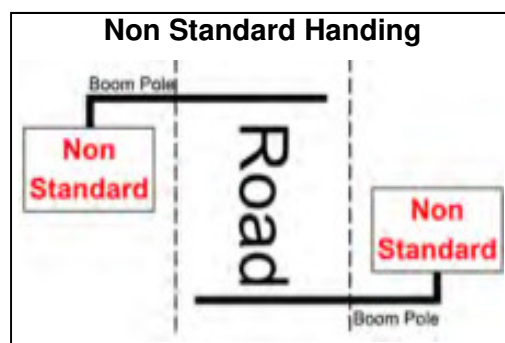
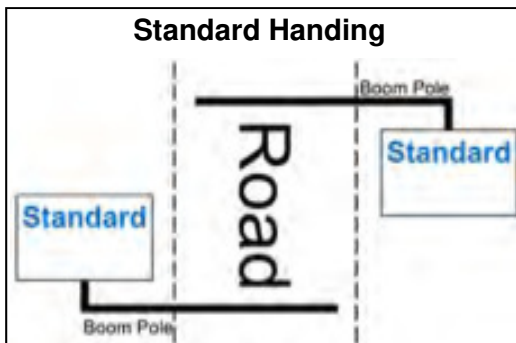

BOOM GATE ACCESSORIES

Programmer	A hand held programmer with LCD diagnostic display.
Loop Detectors	For free exit or safety, LCD diagnostic display.
PE Safety Beams	PE safety beams can be used as an additional safety device or replace the in ground induction loops.
Low Voltage Power	24vdc 1A power supply for safety beams, key pads, radio control.
Articulated Arm	For low ceiling height in underground car parks.
Folding Support Post	Folding boom pole support with gas strut
Magnetic Lock	80 kg's holding force to reduce the risk of vandalism and unauthorised entry by lifting or bending pole.
Foot mounted adjustable height Support Post	Height adjustable support post reduces the risk of vandalism the pole can be securely locked shut with a pad lock when not in use.
Folding Fence	3 meter & 4.5 metre only. The folding fence prevents access by pedestrians under the boom. The fence retracts and folds flat with the pole in the open position
Flashing Light	Amber flashing light fitted to cabinet. This flashes whenever the boom gate pole is operating.
Traffic Lights	Red /green lights or red/green and amber on when pole moving
Sirens	Various types of sirens and flashing light combinations to suit every application
Coin or Token Collector	Coin or token operated for pay car parks.

INSTALLING THE CABINET

- Unpack the boom gate by laying the cabinet on its side with the address label facing up.
- Open the bottom of the carton and fold the lower carton flap under the carton.
- Stand the carton upright and open the top of the carton.
- Remove the hold down bars from the top of the cabinet.
- Lift the carton over the boom gate cabinet.
- Open the cabinet door and remove the foam packing on top of the control panel.
- Remove all other packing and dispose of thoughtfully.
- Determine correct position of the boom gate on the concrete pad.
- 3 and 4.5 meter boom gates are supplied with 4 hold down bars, and 2 square clamps. Two hold down bars fit into the bottom channels of the boom gate cabinet and two are fitted across the top of the channels at right angles. The cross bars are held down using the two square clamps. The 6 metre boom gate has 5 hold down bars and 4 clamps.
- Hold down bars can be fixed by either Dyna bolts, Chemical anchors or Loxins, with a minimum of 100mm penetration into the concrete slab.
- Level the cabinet in both vertical planes with a level, using packing under the base of the cabinet.
- Tighten hold down fixings.

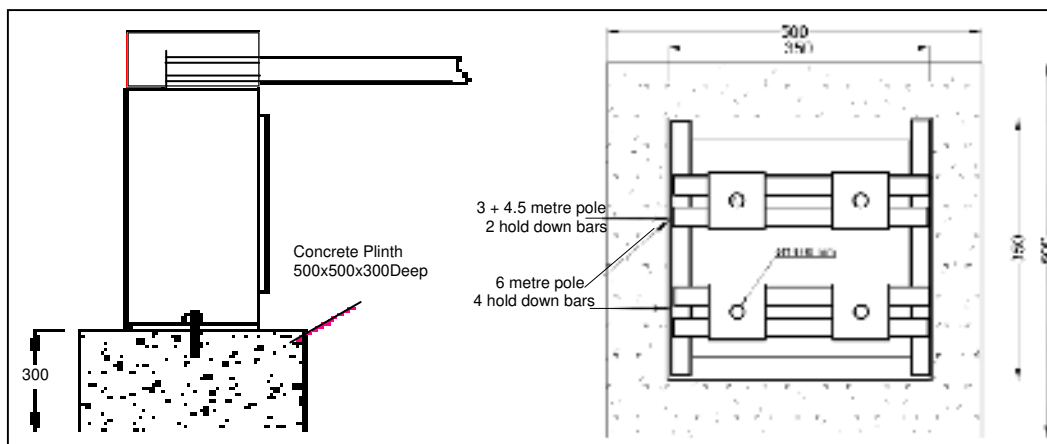

To remove the top cover open the cabinet door & release the cover fasteners.

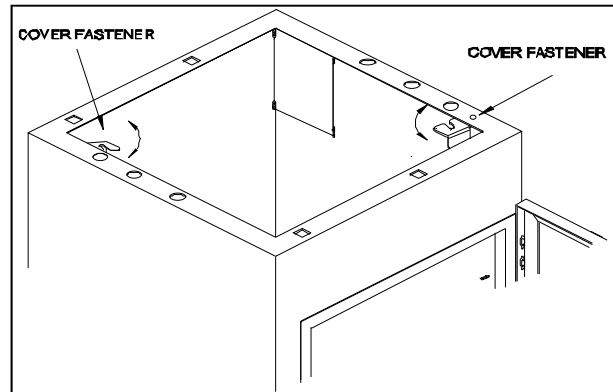

FITTING THE BOOM POLE

- Switch power on and using the toggle switch located on the front of the PL 400 FL logic control raise the boom arm to the open position.
- Fit the boom pole into the boom pole clamp till it is flush with the other end of the pole clamp.
- Tighten the eight clamp bolts **do not** remove grease from bolts as this prevents the stainless steel bolts binding.
- Toggle the boom gate to the close position and fit the boom pole decals as per instructions **OVERLEAF**.

ADJUSTING THE SPRINGS & POLE ALIGNMENT

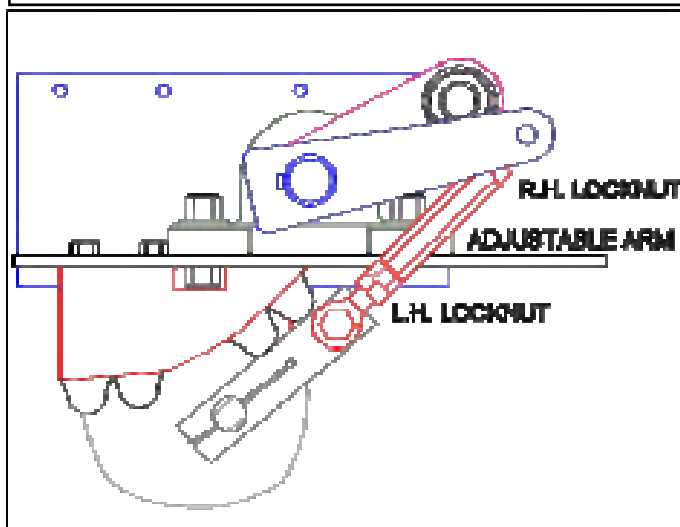

It may be necessary to adjust the springs on site, the top of the threaded rod should be 30 mm from the bar in the spring arm

Do not adjust this to more than 40 mm.

With the pole in the down position you can adjust the alignment by rotating the adjustable arm. Ensure that the lock nuts are tightened after adjustment.

REFLECTIVE DECAL SPACING

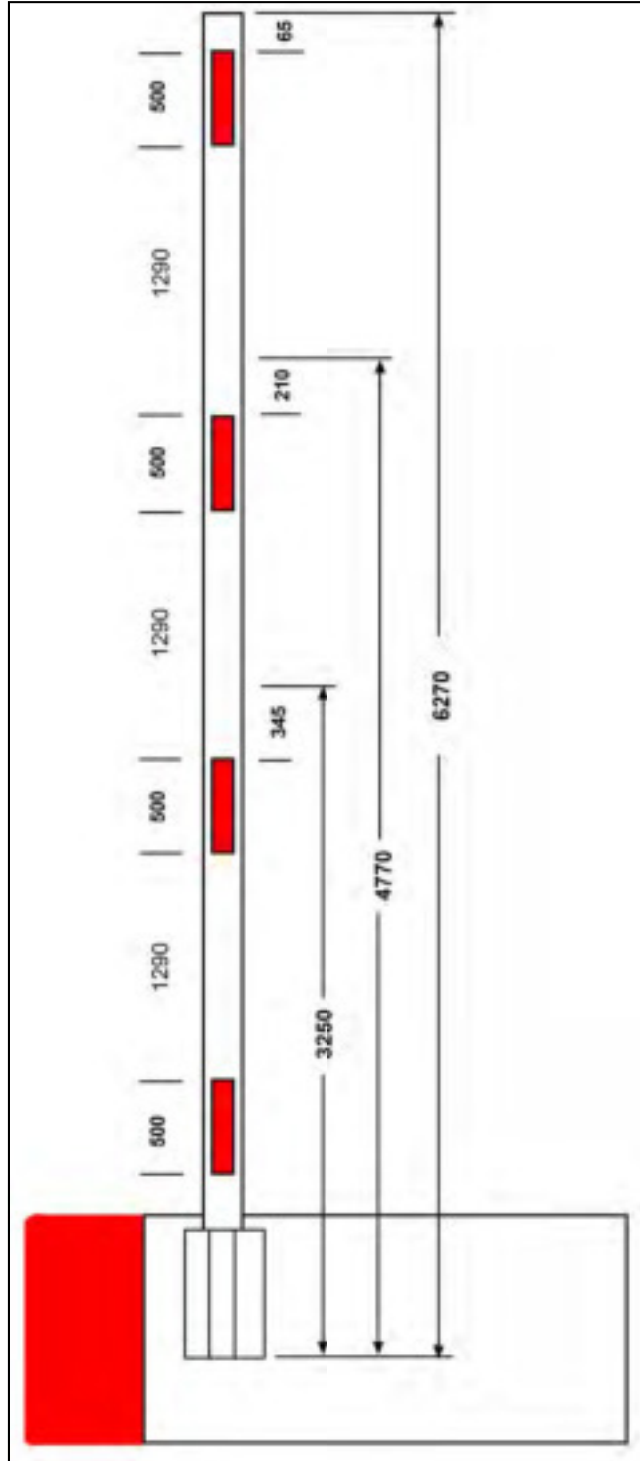

FIXING THE REFLECTIVE DECALS

- Apply 50 mm masking tape to the **RED** side of the decal to prevent the decal stretching.
- Remove the backing from the decal
- Align the edge of the decal with the raised marker on the pole.

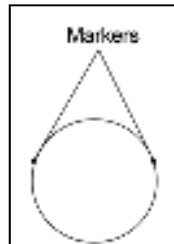

- From one edge, press firmly and slowly move along the length of the decal to remove air pockets
- Then remove the masking tape.

ELECTRICAL INSTALLATION

- A dedicated 10 amp 240v/ac power circuit with earth leakage protection should be supplied by an licensed **ELECTRICAL CONTRACTOR**.
- Check with your local power supply authority or electrical contractor as requirements may change from state to state.
- Have the electrical contractor connect the power supply into the double GPO in the bottom of the cabinet and test.
- Remove the cover from the boom gate cabinet by reaching up and pushing the **cover lock** tabs inwards
- Connect all field wiring e.g. induction loops, PE beams and ticket issuing equipment into the control panel terminals as per the wiring diagram fitted to the inside of the cabinet door or as per individual wiring instructions.

A CLOSED CONTACT TO TERMINALS 5 AND 6 WILL LOWER THE CLAWS
 WHEN THE CLAWS LOWER THE MICRO SWITCH (TERM 3&4) WILL TRIGGER THE BOOM GATE RAISE
 WHEN RAISED THE BOOM GATE LIMITS WILL INTERRUPT THE CLAW SAFETY PE CIRCUIT
 AND SWITCH THE TRAFFIC LIGHT.
 AFTER THE VEHICLE HAS PASSED OVER AND CLEARED THE SAFETY LOOP THE GATE WILL LOWER
 REMAKING THE CLAW PE CIRCUIT - THE CLAWS WILL RAISE 4 SECONDS (USER ADJUSTABLE) AFTER
 THE PE IS CLEARED.

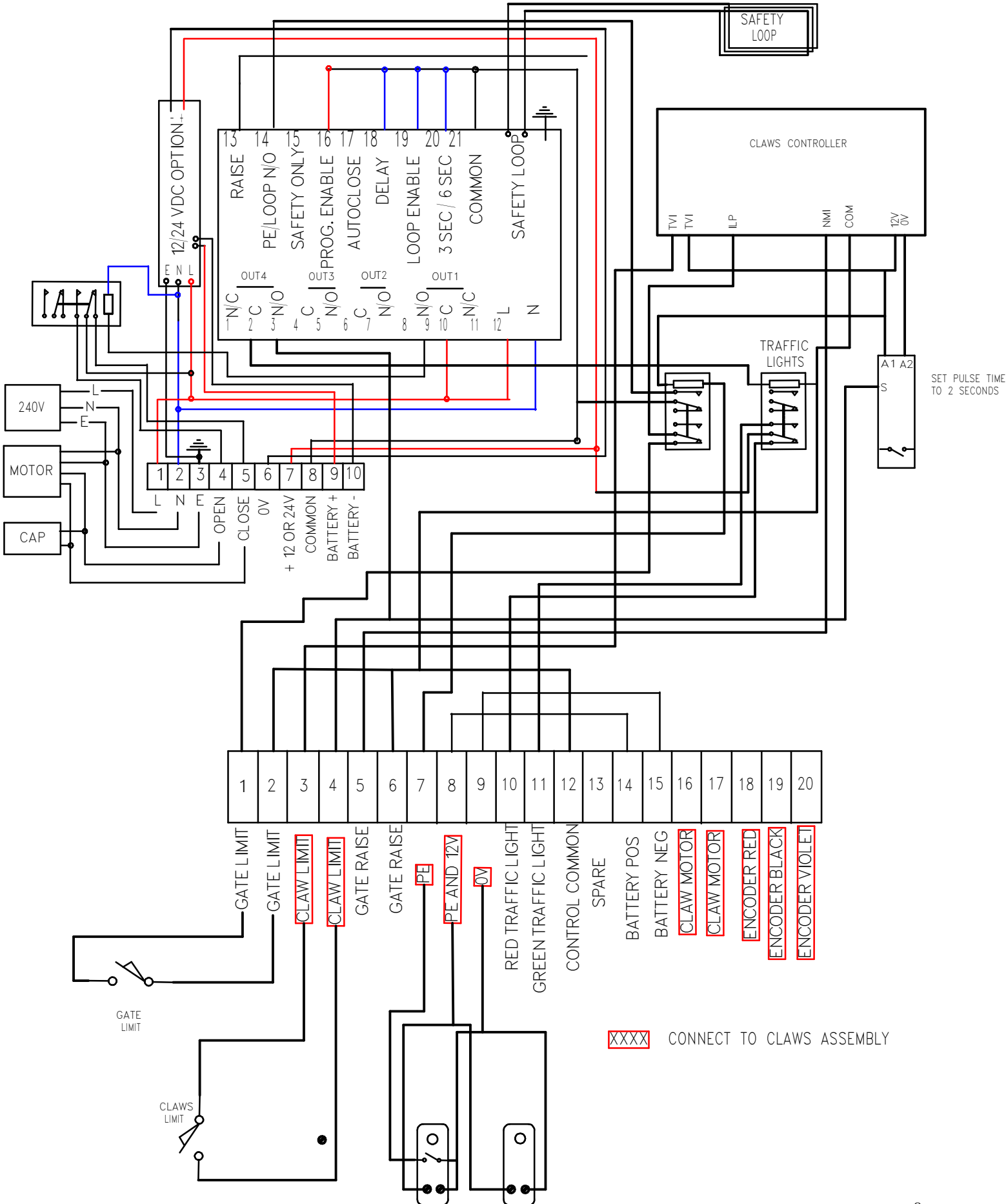

A CLOSED CONTACT TO TERMINALS 5 AND 6 WILL LOWER THE CLAWS
 WHEN THE CLAWS LOWER THE MICRO SWITCH (TERM 3&4) WILL TRIGGER THE BOOM GATE RAISE
 WHEN RAISED THE BOOM GATE LIMITS WILL INTERRUPT THE CLAW SAFETY PE CIRCUIT
 AND SWITCH THE TRAFFIC LIGHT.
 AFTER THE VEHICLE HAS PASSED OVER AND CLEARED THE SAFETY LOOP THE GATE WILL LOWER
 REMAKING THE CLAW PE CIRCUIT - THE CLAWS WILL RAISE 4 SECONDS (USER ADJUSTABLE) AFTER
 THE PE IS CLEARED.

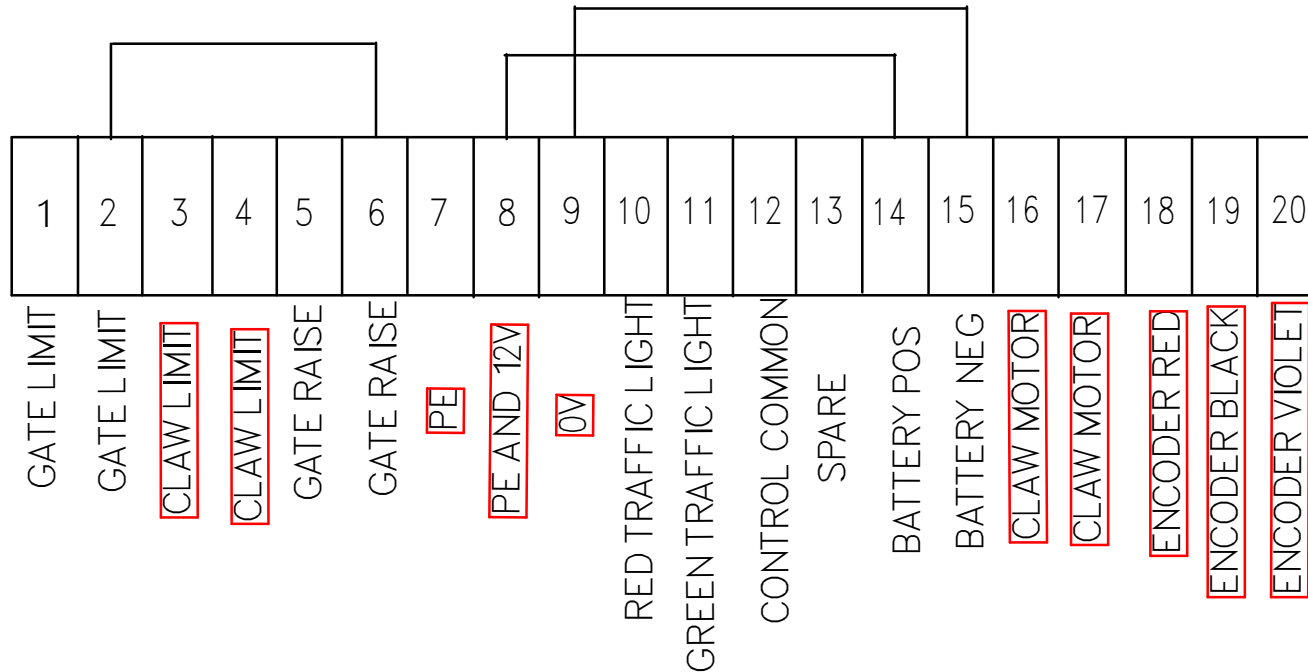

TERMINALS MARKED XXXX CONNECT TO CLAWS ASSEMBLY

	TITLE		DRG NO
WWW.ROTECH.COM.AU	SENTINEL PL BOOM GATE WITH CLAWS INTERFACE	SENTINEL PL GATE CLAWS WIRING CONNECTIONS	PL V8 + CLAWS
PH: 07 3205 1123 E: INFO@ ROTECH.COM.AU			

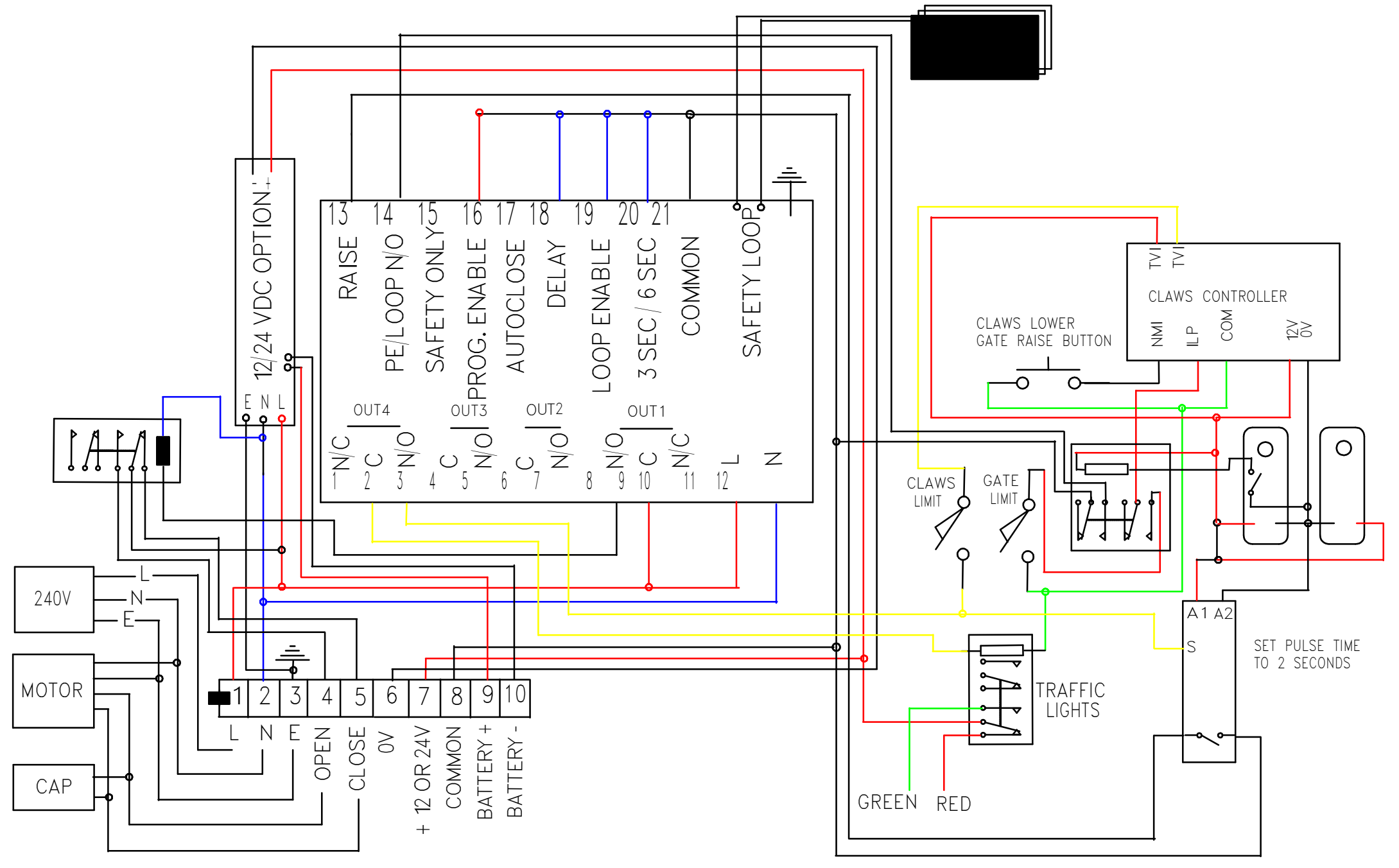

WWW.ROTECH.COM.AU	TITLE		DRG NO
PH: 07 3205 1123 E: INFO@ ROTECH.COM.AU	SENTINEL PL BOOM GATE WITH CLAWS INTERFACE	PL400 LOGIC WITH INBUILT SAFETY LOOP + CLAWS	PL V28 + CLAWS V7

PL 400 FL LOGIC INSTUCTIONS (Rev 1.7) 0814

FACTORY DEFAULTS

To reset all settings to factory default connect terminals **T 13, T 14, T 16 to T 21**

The default settings are:

DETECT SENSITIVITY	0.02% the most sensitive
UNDETECT SENSITIVTY	0.01%
AUTOCLOSE TIME	20 seconds (if no vehicle crosses the safety loop /PE)
PRE MOVEMENT DELAY	2 seconds

INPUTS

INPUT	TERMINAL
1 – RAISE GATE	T13
2 – LOOP / PE (NORM OPEN)	T14
3 – MEMORY INPUT	T15
4 – PROGRAM ENABLE	T16
5 – AUTOCLOSE ENABLE	T17
6 – PRELOWER DELAY	T18
7 – INTERNAL SAFETY LOOP ENABLE	T19
8 – SAFETY ACTIVE TIME (ROLLBACK)	T20
9 – COMMON	T21

The common for all inputs is terminal 21 (T 21)

IMPORTANT: All control inputs are voltage free. Applying an external voltage to these terminals will result in damage to the controller circuit.

OUTPUTS

OUTPUT 1: Gate Motor (use an external relay to switch motor current).

COM - 240VAC

N/C - LOWER

N/O – RAISE

OUTPUT 2: Pre Movement Warning N/O, COM

OUTPUT 3: Gate Moving / Amber Light N/O, COM

OUTPUT 4: N/C -Gate Down / Red Light

N/O -Gate Up / Green Light

COM – Input for light control / Status

Relay 3 & 4 can be used to interlock with external equipment Master / Slave operation or Ticket Machine control or Card Reader enable.

CONTROL INPUTS

Modes of Operation

There are 3 modes of operation available – Standard, Slave, and Toggle.

Standard Mode: is the default operation with the controls as described above.

Slave Mode: is selected by changing the auto close time to zero. A signal to T13 (raise) will cause the barrier to rise. Removing the signal will cause the barrier to lower immediately – PROVIDED THE Internal or external loop / PE is not activated.

Toggle Mode: is selected by connecting T13 and T15. A pulse to T13 will alternately raise and lower the barrier (provided a safety device is not activated). The toggle input to lower the barrier will only operate if the barrier is fully raised and there is no safety input activated.

If the lower toggle state is activated and a safety device is triggered the barrier will remain raised until the safety input is cleared. If a safety device is triggered whilst the barrier is lowering (after a lower toggle input) the barrier will immediately raise and remain raised until another toggle input is made.

Please note: the barrier will not respond to a lower toggle input until the raise travel timer has expired (this is to prevent the barrier being inadvertently lowered by a double press on a push button or a dirty control contact).

Control Inputs

Raise Gate (T 13 – T 21): a momentary Input of between 0.2 – 1 second will raise the gate. In some installations an input longer than 1 second may cause operational problems with the vehicles passing through the area before the raise signal is removed – this is characterised by the gate intermittently staying raised. The only time this input should be longer than 1 second is when the controller is being configured for slave or external logic control modes.

Second Loop Input or Safety PE (T 14 – T 21): Gate will lower when the signal is removed – trailing edge N/O Input. If T14 is retriggered within the safety active time (rollback time) the gate will raise for as long as T14 is held and then lower immediately. Once the safety active time (rollback time) has expired this input is disabled until the gate is raised again on T13

Memory Input MI (T 15 – T 21): connecting T15 to T 21 will enable Memory input on the raise gate signal. To reset the count operate the toggle switch once. The gate logic will count the raise input signals and then decrement the count for each trigger of the loop or PE input T 14 .The memory of this input is volatile – that is it will reset if the power is cycled to the gate.

CONTROL INPUTS

Auto Close Enable (T 17 – T 21): connecting T 17 to T 21 enables the auto close function. This means the gate will close after a set time if no vehicle triggers either the internal loop or external input - Loop / PE (T 14). The factory default is 20 seconds. This time is user adjustable from 0 – 300 seconds. This function can be switched on and off by an external device such as a time clock or alarm panel.

Pre Lower Delay (T18 –T 21): connecting T 18 to T 21 enables the Pre Lower Delay function. This function operates relay output 2 and delays boom arm movement for a set time.

This function is designed for installations where a warning device (flashing light, siren etc.) is required to warn of impending boom arm movement. The default time is 2 seconds. This time may be changed by the user.

A Pre Raise Delay function is available but must be requested by special order.

Internal Safety Loop (T 19 – T 21): connecting T 19 to T 21 enables the internal safety loop. : This internal loop detector replaces the need for an external loop detector. The default values are normally suitable - though they can be changed by the user. LED 2 will flash rapidly whenever a vehicle is detected.

LED 1 and LED 2 will flash alternately if a loop fault is detected.

In the event that the internal safety loop cannot be used – remove the link from T 19 – the logic will now ignore the internal loop condition and only monitor the Input 2 (T 14) for safety loop / PE function.

Safety active time(rollback) (T 20 – T 21): The roll back timer enables the safety device to re trigger the gate when closing. The default time is 6 seconds. Connecting T 20 to T 21 changes this time to 3 seconds.

Note: this time is used to select the gate arm moving time output on Relay 3.

Adjusting Internal Loop Time delay on Close

The default time is 0.5 seconds.

Loop Delay is the length of time the detector will hold after detection is finished. This function is useful for tracking high bed vehicles or trailers.

To set the Loop Delay function enter program mode – both LEDs will illuminate.

Momentarily jumper 1 to com – this resets the temporary memory.

Move the toggle switch from the centre position to the raise position and back again – repeat for the desired delay (refer table below). Momentarily jumper 2 to COM – this loads the new value into non-volatile memory.

Switch Operations (Seconds)	1	2	3	4	5	6	7	8	9	10
Filter Delay Time	2	4	6	8	10	12	14	16	18	20

If the factory default settings are satisfactory ignore the following pages 12-13 of this document.

User Selectable settings in program mode

IMPORTANT: when in program mode the Logic Controller is still running sections of the program and as such may operate the outputs. Some of these operations may be undefined. Therefore it is necessary to ensure that no pedestrians or vehicles are in the area when making these changes. Ensure the operator is clear of the mechanism when making adjustments to the controls.

IMPORTANT: When changing parameters link only the inputs for the function to be adjusted. Linking inputs other than those described will result in writing incorrect values into memory causing operational malfunction. If it is suspected that this has occurred – perform a factory reset – then reload user values as required.

Enter Program Mode: Connect **T 16 to T 21** This puts the unit into program mode, keep these two terminals connected while you select the functions below. Only remove the program link after making **FINAL** changes to all the parameters you wish to change. Once changed these values are stored permanently unless the unit is factory defaulted.

When in program mode - both Raise and Lower LEDS will illuminate

Adjust Auto Close Time

- Enter program mode and connect **T 17 to T21**.
- If the Auto Close time has not been manually changed – the time will be 20 seconds (factory default).
- The Auto Close timer will lower the boom irrespective of whether a vehicle has passed over the loop..
- First reset the timer, **momentarily** jumper **T 13 to T 21** (Gate Raise input whilst in program mode) this resets the time to zero.
- Use the toggle switch to add or subtract time from the timer.
- For each operation of the switch to the **Gate Raise** position: 2 seconds are added to the auto close time.
- For each operation of the switch to the **Gate Lower** position: 2 seconds are subtracted from the auto close time.
- E.G. to set the time for 6 sec - jumper **T 21** to input **T 17** and switch the toggle switch to raised position and back to centre position 3 times.
- To load the time into permanent memory - **momentarily** connect **T 21** to **T 14** (loop) whilst still in program mode. The time **must be** loaded in memory for the change to take effect.
- Remove jumper **T 17 to exit auto close**, you are still in program mode if you wish to adjust other parameters go to . If you wish to leave program mode disconnect **T16 to T21**.

Adjusting Pre movement warning time

– Enter program mode and connect **T 18 - T21**

This function is set in the same way as the auto close time.

NOTE: do not have **T 15 T 17 T 19** connected.

To reset the timer, momentarily jumper **T 13 to T 21** (Gate Raise input whilst in program mode) – this resets the time to zero.

Use the toggle switch to add or subtract time from the timer.

For each operation of the switch to the Gate Raise position: 2 seconds are added to the pre flash time.

For each operation of the switch to the Gate Lower position: 2 seconds are subtracted from the pre flash time.

To load the value into memory - momentarily connect **T14** (loop) to **T 21**

(COM) The value must be loaded into memory for the change to take effect.

These settings are stored and retained when the power is removed.

Adjusting Internal Loop Detector

Enter program mode (T16 - T21) and connect **T19 to T 21** to enable this function.

If there is a loop fault LED 1 and LED 2 will flash.

When a vehicle is detected LED 2 will flash.

There are two adjustments for the inbuilt detector, loop sensitivity and loop filter.

Loop Sensitivity changes the point at which the loop will detect a vehicle. This is measured as a percentage of frequency change. There are 8 levels of adjustment ranging from 0.02% to 0.5%. the most sensitive is 0.02% and the least sensitive is 5% The default setting is 0.02%

ASB (Automatic Sensitivity Boost)

Undetect sensitivity (ASB) is automatically set to twice the detect sensitivity.

This function enables the reliable detection of high bed vehicles.

The 9 loop sensitivity levels are:

Switch operations	0	1	2	3	4	5	6	7	8
Sensitivity %	0.02	0.04	0.08	0.16	0.32	0.64	1.28	2.56	5.12

Common (T 21): this connection is a common point for all input control functions

Momentarily connect **T 13 – T 21** (this resets the temporary memory) Move the toggle switch from the centre position to the raise position and back again – repeat for the desired sensitivity. Then momentarily jumper 2 to COM this loads the new value into permanent memory.

GROUND LOOPS AND LOOP DETECTOR MODULES

1. The loop and feeder should be made from 1.5mm sq. insulated copper wire. The leader should be twisted tightly with at least 20 turns per metre. Feeders that may pick up electrical Noise should use a screened cable with the earth shield connected to the loop detector at pin 9.
2. The loop should be either square or rectangular with a minimum distance of 1 metre between opposite sides. Large loops with a circumference greater than 10 meters should use 2 turns of cable, while smaller loops with a circumference less than 6 metres should use 4 turns of cable. When two loops are in close proximity to each other it is recommended to use 3 turns in one loop and 4 turns of cable in the other.
3. Cross talk is a term used to describe the interference between two adjacent loops. To avoid this loops should be at least 1 metre apart and on different frequency settings.
4. For loop installation, slots should be cut in the roadway or concrete 4mm wide and 30- 50 mm deep. Corners should be cut at 45° to prevent damage to the cable.
5. For best results the loop and feeder should not have any joins. Run the cable from the loop detector around the loop the desired amount of turns then back to the loop detector, remember that when you twist the leader that the cable will shorten so allow enough cable to run back to the loop detector.
6. After the loop cable has been placed into the slot, fill the slot with epoxy compound or bitumen filler.

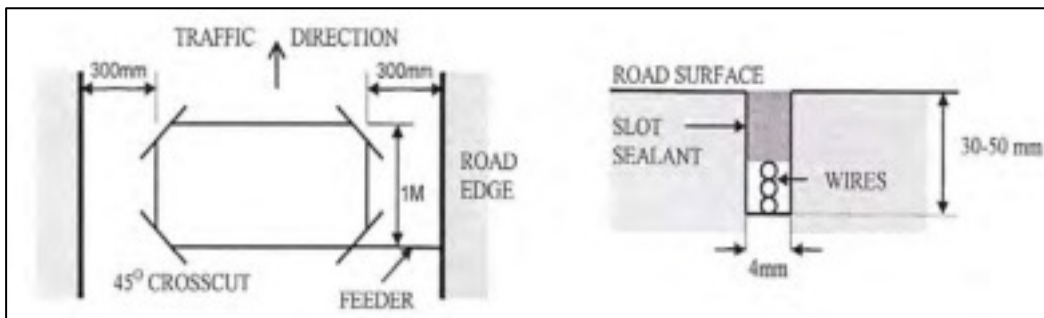

LOOP DETECTOR TECHNICAL DATA

OPERATING POWER.	LD 100 200-260 V/AC 50Hz (1.5 VA.)
MAX RELAY CAP.	0.5 AMP – 220V/AC.
RESPONSE TIME.	120m/sec.
FREQUENCY RANGE.	15 -1500 μ H
DIMENSIONS	80(H) X 40(W) X 79(D)

LOOP FAULT FINDING

If LED 1 and 2 on the PL400FL are flashing there is a problem with the loop.

On the external loop detector LD 140 if the detect LED flashes erratically or stays on there is a fault. If the loop inductance is too small it shows SHT on the display.

Some of the common problems are:

- a. The loop wires have a short circuit. Check the wiring.
- b. The loop inductance is too low. More turns must be added
- c. The loop inductance is too high. This is seldom a problem as most loops have a inductance of less than 500 μ H. A solution is to reduce the number of turns on the loop.
- d. The loop is open circuit. Check the wiring.

If the detector is erratic the problem may be more difficult to find. The first step is to check the loop wiring. Many intermittent problems can be attributed to poor wiring connections and even movement in the ground loop. The next step is to change the loop frequency, and finally it may be necessary reduce the loop sensitivity . Details of the adjustment for the PL 400 are on page ??? And the details for the LD140 are on the instructions supplied with the boom gate

Care must be given to the placement of the loop. The loop should not be put below reinforcing mesh, should be kept away from any metal object such as a manhole and should also not be within 1 metre of sliding gates, roller doors. or any metal object likely to move or vibrate. High power electrical cables and some types of electrical equipment can also cause problems.

FITTING BOOM GATE ARTICULATED ARM

Boom Poles are supplied in 3, 4.5, or 6 metre lengths.

1. Drill 8mm holes in cabinet as shown in Fig.1. Fit the support bracket To the boom gate cabinet with the hardware supplied.

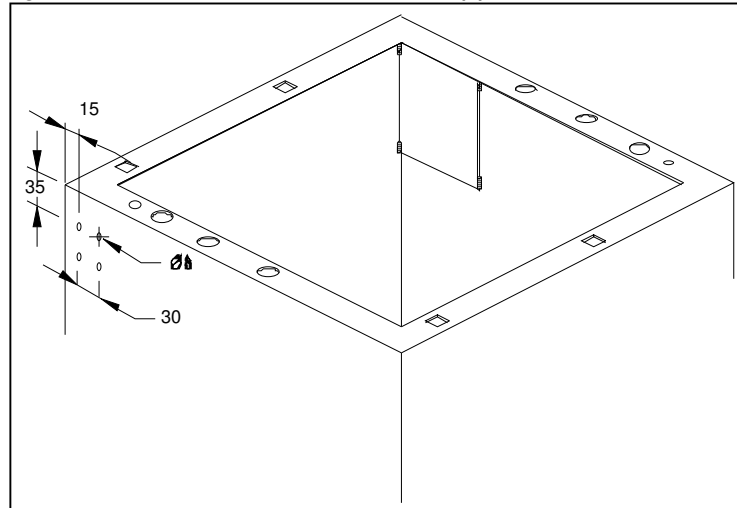

2. Cut boom pole A using the formula below.
 - MC = Maximum Clearance.
 - MC = VH + VCH.
 - VCH = Vehicle Clearance Height.
 - VH = Vehicle height
 - Length Pole A. $MC - 1215 = A$
 - e.g. (Max. Clearance = 2800.) $2800 - 1215 = 1585\text{mm}$.
3. Release spring tension by undoing the top nut to the end of the threaded rod on each spring.
4. Switch power ON and using the toggle control on the front of the logic control module position the boom in the down position. Fit pole A into the boom clamp and tighten.
5. Fit the articulated arm to the other end of boom pole A. **Note** - Use masking tape to hold the joints together while setting up.
6. Fit the turnbuckle assembly to the cabinet side of the cabinet support bracket midway down the slot and tighten so the assembly will still swivel.
7. Fit the upper rope clamp to the articulated arm and tighten so that the clamp will still swivel freely.

8. After cutting fit the rope into the upper rope clamp and tighten all grub screws
9. Cut pole B to suit entrance width and fit to the articulated arm.
10. Level pole B with pole A by adjusting the turnbuckle then tightening both lock nuts.
11. Toggle boom gate to the open position.
12. Level pole B by adjusting the height of the turnbuckle assembly in the slot on the cabinet support bracket.

DO NOT ADJUST THE TURNBUCKLE.

14. Retention springs as per section on PAGE.
15. Check boom is level in the open and closed positions. Toggle boom to the closed position and fix pole A & B to the articulated arm, insuring that the articulated arm is vertical, by either rivets or self drilling screws and remove all masking tape.

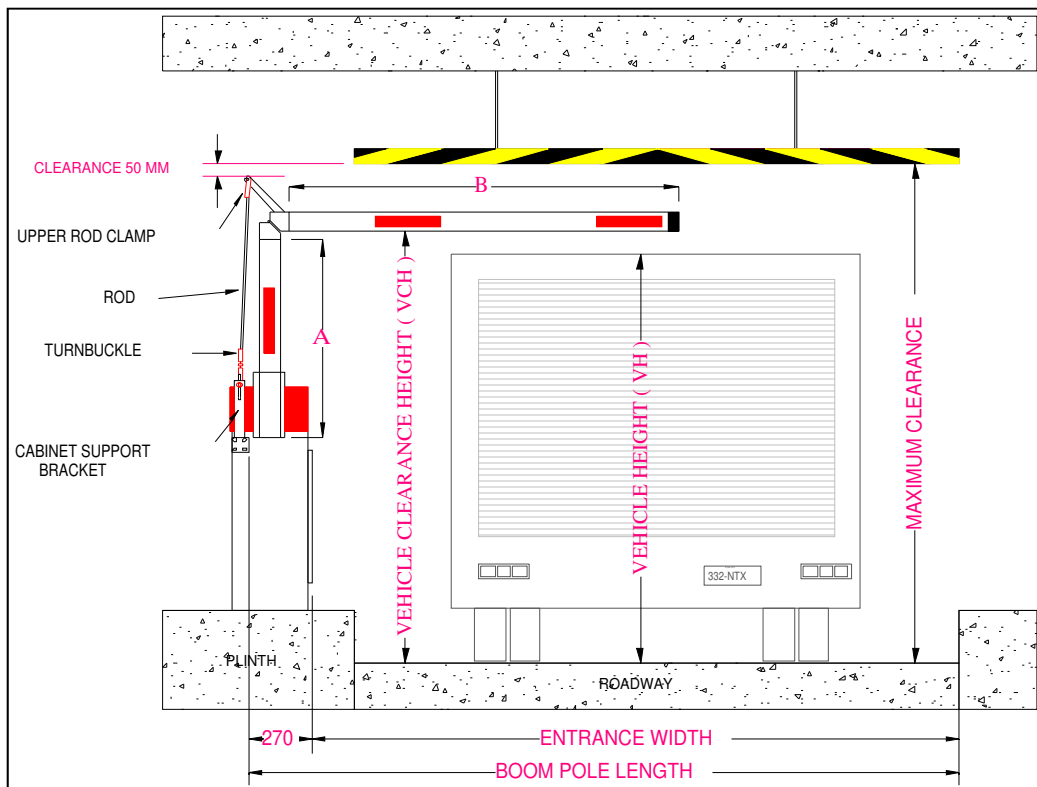

FOLDING SUPPORT POST

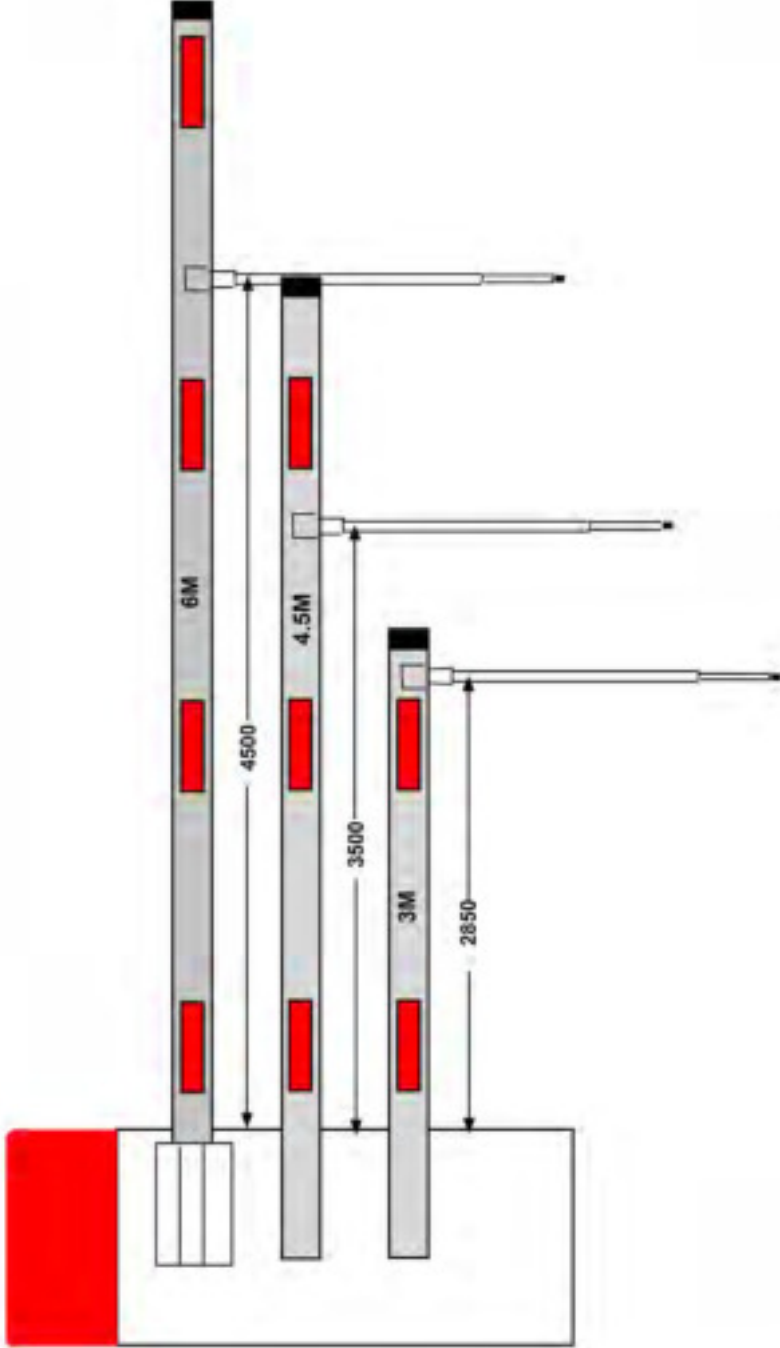

FOLDING SUPPORT POST

If the folding support post has been supplied with a boom gate from the manufacturer all springs are pre-set.

If the folding post has been supplied to fit to an existing boom gate then the springs need to be changed and adjusted as shown below.

<u>SIZE</u>	<u>SPRING TYPE</u>	<u>QTY</u>
3.0	Heavy Duty	1
4.5	Heavy Duty	2
6.0	Heavy Duty	4

1. Fit the folding support post at the following distance
 - 3.0 m pole 2850 mm from the end of pole to the centre of the post bracket.
 - 4.5 m pole 3500 mm from the end of pole to the centre of the post bracket.
 - 6.0 m pole 4500 mm from the end of pole to the centre of the post bracket.
2. Fit folding support post to boom pole and adjust springs as in installation instructions page 3.
3. Toggle the boom gate to the closed position.
4. Adjust boom pole for level by adjusting the adjustable arm On the motor base and compressing the gas strut on the folding support post by 50 mm ensuring the boom pole is still level.
5. The folding post should be adjusted by sliding the lower inner tube up or down to compensate for the difference in height between the boom gate and the surface of the road.
6. Initially only tighten one grub screw. When the boom gate closes the shock absorber should compress and hold the boom pole in the horizontal position.
7. When the adjustments have been completed lock both grub screws in position.

SENTINEL PL SERIES - BOOMGATE SPARES

Item Number	Description
52118	Hold down kit (3+4.5m boom gates)
52119	Hold down kit (6m boom gates)
564	3m Boom Pole
565	4.5m Boom Pole
566	6m Boom Pole
573	TM 10 Motor (3+4.5m boom gates)
574	TM 5.5 Motor (6m boom gates)
583	Hard Stop 16mm
5208	Boom Clamp & SS Bolts
5363	Folding leg only (no springs)
5639	Red Decals
5761	Rod end LH
5762	Rod end RH
5775	Boom Coupler
5776	Adjustable arm
5778	Aluminium motor arm
52111	Danger Decals
52112	Keep Hands Clear Decal
52113	Mild Steel Cabinet Only (no cover)
5200	Mild Steel cover only -
5202	Stainless Steel Cover Only -
52114	Stainless Steel cabinet (no cover)
52115	NV Lock & Latch
52116	NV Spare Key (Each)
52117	NV Black Hinges

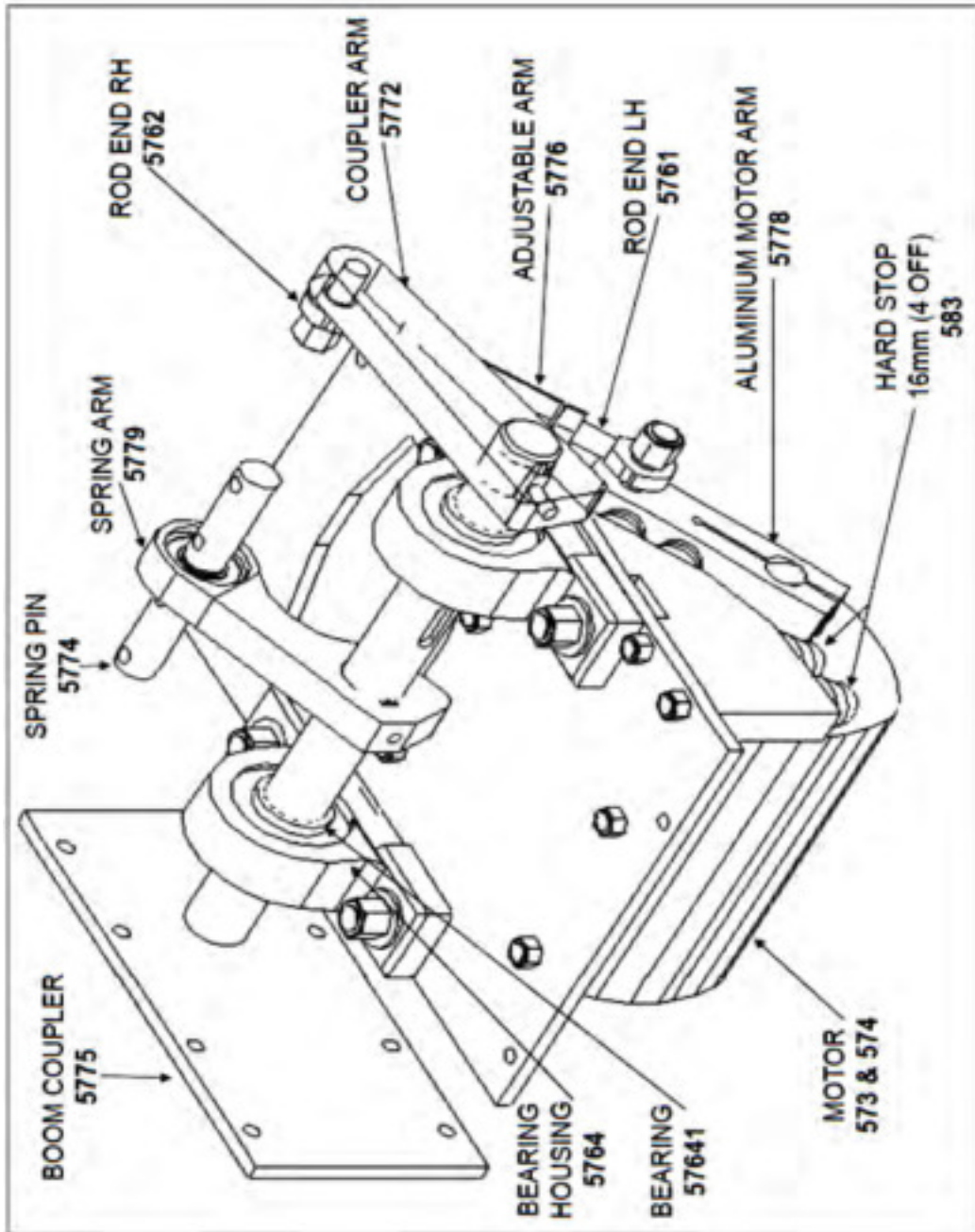

SERVICE INSTRUCTIONS – SENTINEL BOOM GATES

WARNING

**BOOMGATE STARTS AUTOMATICALLY.
ISOLATE POWER BEFORE SERVICING.**

1. The Sentinel NV Series boom gates need to be serviced every 6 months in high volume installations and every 12 months in low volume installations.
2. Inspect the cabinet for any signs of damage; clean with a mineral Clean and repair any paint damage with a zinc based paint.
3. Operate the boom gate and observe the motion of the boom pole. If the pole dips as it starts to open the aluminium motor arm has gone over centre, Replace worn stop rubbers and check motor arm for Alignment. Level pole as in section 5 if required.
4. Test spring tension. Lower the boom pole with power ON. Then switch power OFF. The boom pole should rise to the fully open position smoothly and remain open. If the pole does not open fully then more tension is required on each spring. If the pole opens violently then less spring tension is required.
5. Check the position of the boom pole. If it is not level adjust the adjustable arm until it is level. After adjustment, check that the adjustable arm is in line with the aluminium motor arm when the boom pole is in the down position. Test by trying to lift the boom pole up with power ON. Properly adjusted you should not be able to open the boom gate.
6. Check stop rubbers for cracks or wear and replace if necessary.
7. Check the cabinet hold down bars are secure and that the concrete surface is in good repair.
8. Check and tighten all bolts, grub screws and mechanical fixings.
9. Check and tighten all electrical connections. Inspect leads and cables for damage. Replace as required.
10. Check that the loop cables are twisted tightly together.
11. Check condition of roadway and loop sealing.

