

TriStar F21 Full Height Turnstile

Battery back-up system is now standard and solar power optional



The Australian made TriStar full-height turnstile is a bi-directional turnstile based on the successful Sentinel FH design but with many new features and improved operation.

The only Australian Made turnstile with battery back-up as a standard feature.

The soft start and stop feature makes this turnstile easier to use than ever, even a small child can operate it.

With a portable base and solar power you can install the TriStar in the most remote locations.



Rotor Mechanism: The new design F21 turnstile incorporates a high capacity drive mechanism, which will support all types and sizes of rotating arms without compromising on speed and security.

Increased internal height to 2100mm and wide entrance allows for personnel wearing hard hats and carrying tools.

Status Indication System: With an increased requirement for security monitoring the new status indication system allows the customer to see when the turnstile is closed and if the entry (or exit) is freewheeling. The emergency key release can also be monitored.

Unique Relay and Battery Back-up Operation: On power failure the built-in relay automatically initiates the battery back system and sets off a warning siren or optional flashing light. This means in situations where power is down the turnstile can continue to function normally for up to 3000 cycles without mains power.

In the event of a power failure a loud siren (95 dB) is activated indicating that the turnstile is now operating on the battery back up system

TriStar F21 Full Height Turnstile features:

The TriStar FH is the first Australian Made product of its type, created to provide customers with a safe and secure method of access control with multiple optional features including:

- Optional wide access gate allows for bulky goods or wheelchair access
- The mechanical drive system has a 5 year conditional guarantee
- Solar power for remote sites or where there is no mains power
- Card reader mounting brackets suitable for reader and intercom
- Turnstile roof prevents people climbing over the turnstile
- Status indication for security monitoring
- Portable base with fork lift pockets for easy transportation.

Technical Specifications

Specification	TriStar FH Turnstiles
Throughput	15 people per minute
Duty Cycle	100%
Current	1 Amp @ 240 VAC
High Capacity Mechanism	Mechanical pawl and rollers non-reversible after 33°
Solenoid	12V DC
Battery back up when power fails is standard	Operates as normal for 3000 Operations
***Power Failure Options without battery back up	<ul style="list-style-type: none"> ■ Locked entry - free exit ■ Locked exit - free entry ■ Locked in both directions ■ Free wheel in both directions

*** These options must be specified when ordering and cannot be changed on site.

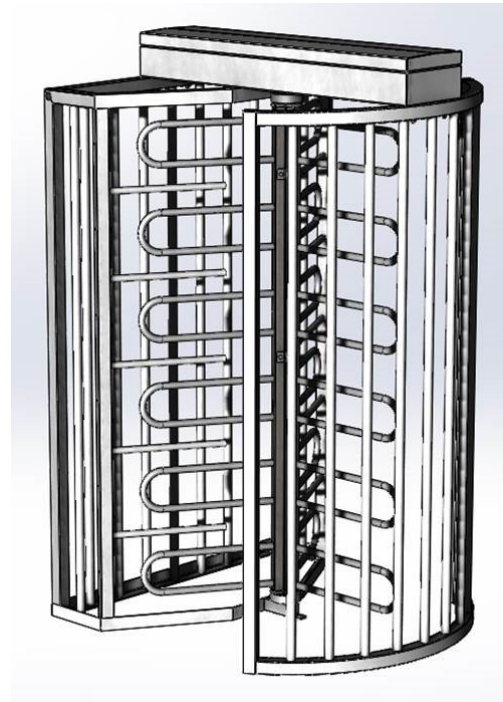

Dimensions

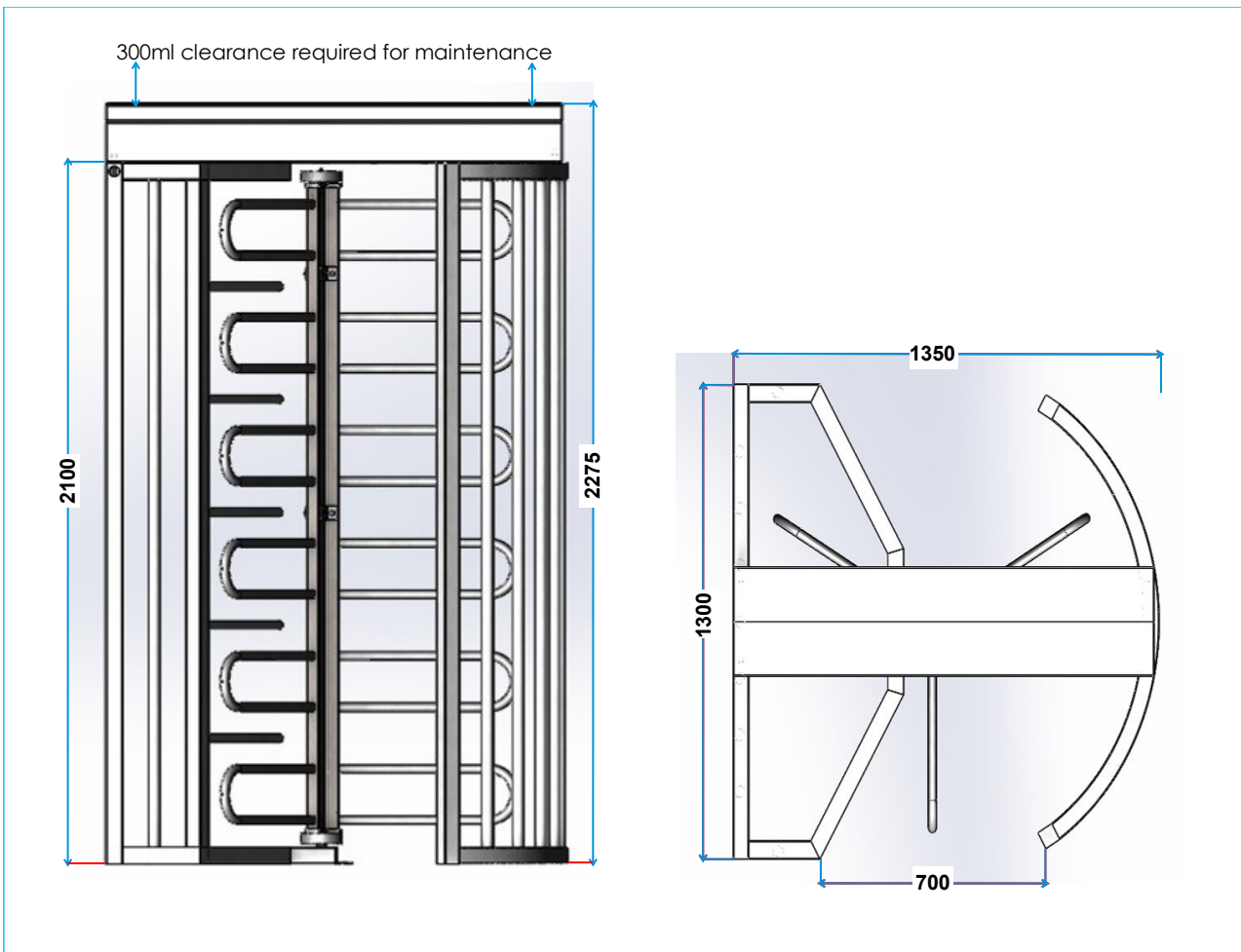

Wide Access Gate

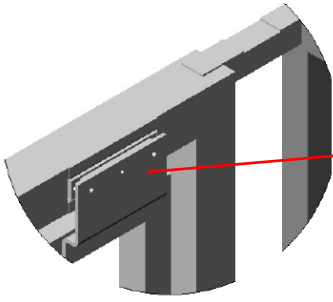

Magnetic Lock
holding force = 200 kg

Gate construction
compliments the turnstile
design

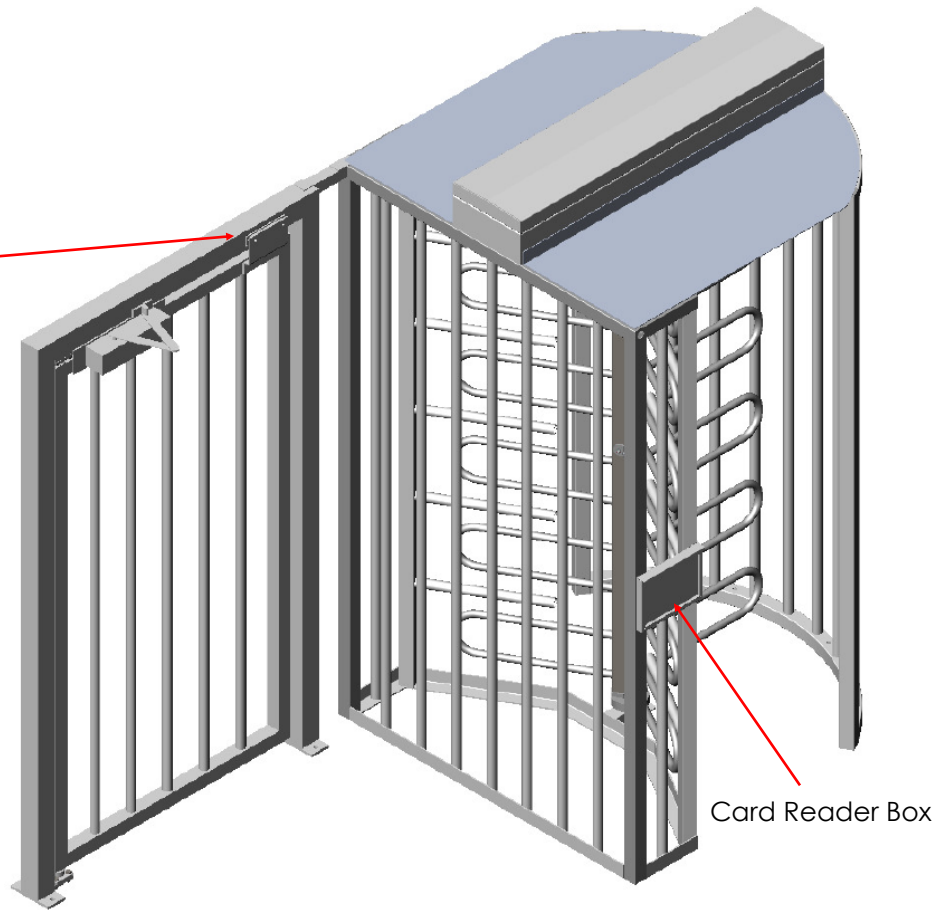

Dimensions

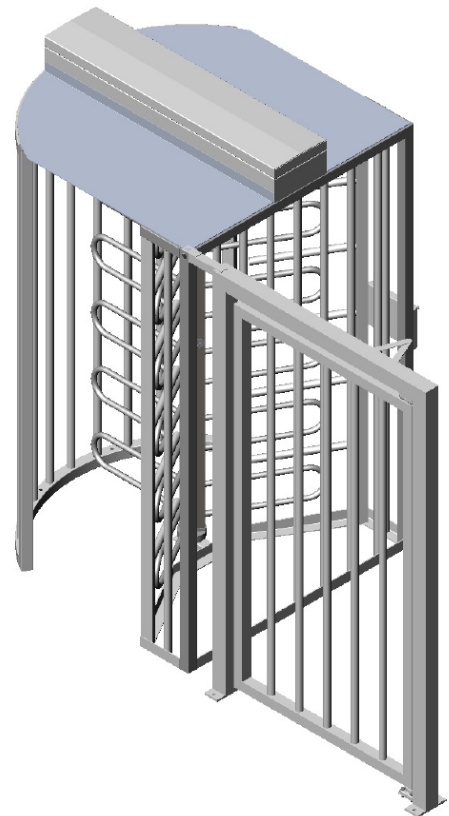
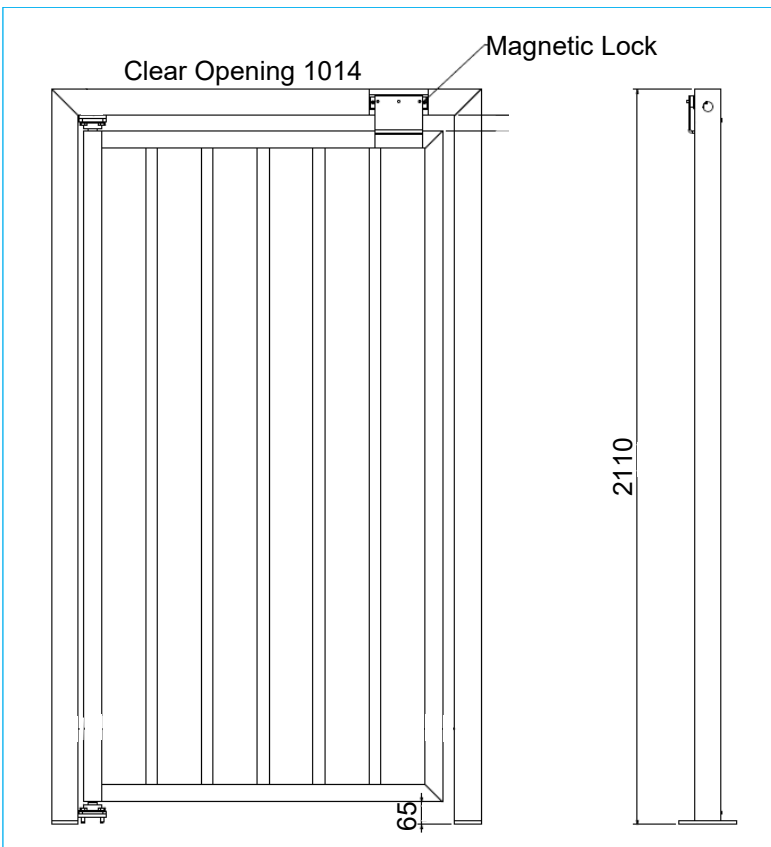

Rotech supply all forms of door and gate automation

Vehicle Access Control

- Booms Gates
- Sliding Gates
- Swing Gates
- Industrial Door Openers
- Solar Powered Gate Openers

Pedestrian Access Control

- Full Height Turnstiles
- Waist Height Turnstiles
- Supermarket Gates/Turnstiles
- Wheelchair Access Gates
- Rapid Access Gates

Fast | Safe | Secure

For more information: t: +61 07 3205 1123 | www.rotech.com.au | e: info@rotech.com.au

V0418