



Vehicle Access Control
Pedestrian Access Control
Safety & Security Equipment

T +61 7 3205 1123

www.rotech.com.au

e: info@rotech.com.au

BIONIK AG and BKBOOM GATE

Electrical Quick Set-Up Instructions

(V1219)



NOTE: The Quick Set-Up Electrical Instructions below provide basic information for setting up the Bionik AG and BK Automatic Boom Gate.

For more detailed installation information please refer to the full set up instructions document.

QUICK SET UP ELECTRICAL INSTALLATION

The following quick set-up instructions are modified extracts from various sections of the original Electrical Installation Instructions from Roger. They explain the installation procedure using local terminology.

All the new design boom gates from Roger are now described as Bionik but in Australia we will keep the old designations to prevent confusion. In the Roger manuals the AG2 is shown as Bionik type KB followed by the size 004 or 006. The new small footprint Bionik is shown as BI followed by the size 003, 004.

When the boom gate is shipped the control panel is programmed with a factory setting which caters for 80% of installations.



Warning: DO NOT make any adjustments to the control panel and DO NOT fit any auxiliary items such as PE beams before you have run the auto learn.

1. Function buttons and display

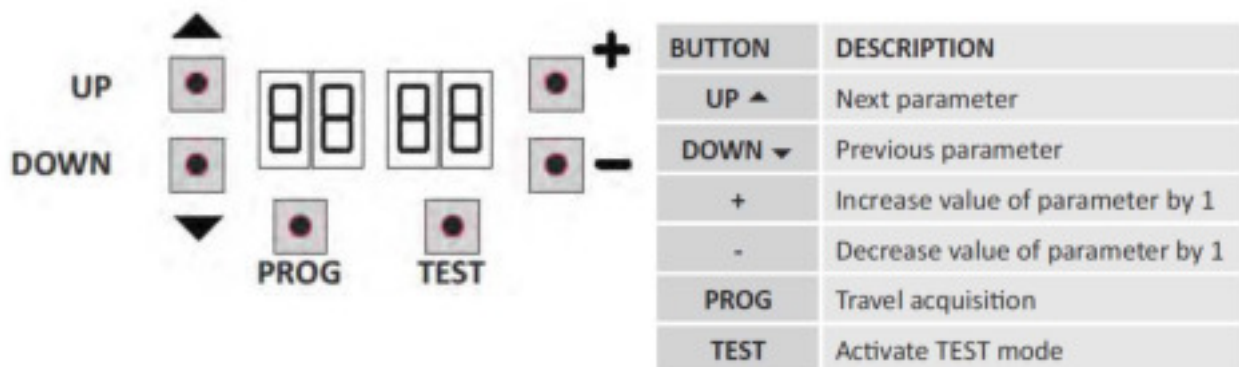

- Press the UP ▲ and/or DOWN ▼ buttons to view the parameter you intend to modify.
- Use the + and - buttons to modify the value of the parameter. The value starts to flash.
- Press and hold the + or - button to scroll quickly through values, to modify the parameter more quickly.
- To save the new value, wait a few seconds or move onto another parameter with the UP ▲ or DOWN ▼ button. The display flashes rapidly to indicate that the new value has been saved.
- Parameters can only be modified while the motor is not running. Parameters can be viewed at any time.

2. Switching on or commissioning

Switch on power to the control panel.

The firmware version of the control unit is displayed briefly.

Version installed r3.45.

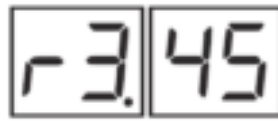

Immediately afterwards, the display enters the command and safety device status mode.

Now set up the installation by configuring the parameters as needed.

For installations with two opposing barriers, settings must be made from the MASTER controller. Only the parameters RO and 13 may be modified from the SLAVE controller.

3. Display function modes

3.1 Parameter display mode

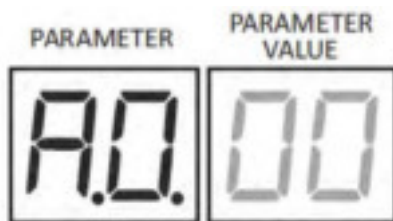

See chapter 5 for detailed descriptions of parameters

3.2 Command and safety device status display mode

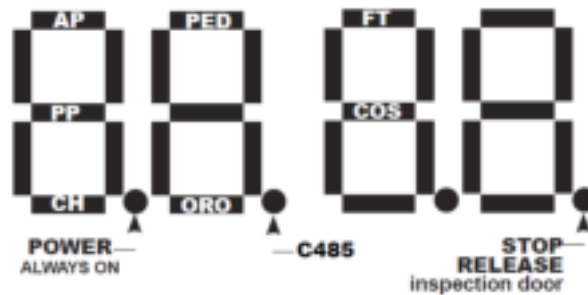

DISPLAY FUNCTION DESCRIPTION:

- AP** Input (NO) Open Command
- PED** Input (NO) Partial Open or Partial Open or in Parking Mode Loop (NC)
- PP** Input (NO) Open / Close Toggle (See Parameter A4)

- CH** Input (NO) Close Command
- ORO** Input (NO) Time Lock - When Input is activated, Barrier opens and remains open until the time period finishes.
- FT** Input (NC) for Photo cell or Safety Loop
- COS** Input (NC) or 8K Ω OHM for sensing edge on Barrier. If not used Jumper 23 (COS) to 22 (COM) or set parameter 73 00

SAFETY DEVICE STATUS:

The safety device status indicators on the display (segments FT= photo cells, COS = sensing edge or STOP/RELEASE position) are normally on. If an indicator is off, the relative device is in a alarm state or is not connected. If the indicator is flashing, the relative device has been disabled with a specific parameter.

3.3 TEST mode

The TEST mode is used to test activation of the commands and safety devices with visual confirmation.

To activate the mode, press the TEST button with the automatic barrier system at rest. If the barrier is moving, pressing TEST stops the barrier. Pressing the button again enables TEST mode.

The flashing light and the barrier open indicator lamp illuminate for one second.

N.B. For installations with two opposing barriers, if the TEST button is pressed for the SLAVE barrier, the normally.



The command signal status is shown on the left hand side of the display for 5 seconds, ONLY when the respective command signal is active (AP, CH, PP, PE, OR).

For example, if the open command is activated, the letters AP appear on the display.

The status of the safety devices/inputs is shown on the right hand side of the display. The number of the terminal relative to the safety device in alarm state flashes.

Example: STOP contact in alarm state.



00	No safety device in alarm state or barrier waiting for command.
21	STOP contact active. Release device open. Barrier inspection hatch open.
23	Sensing edge COS not connected or not functioning.
24	Photo cell FT (only visible for MASTIER barrier) not connected or not functioning.
r5 (rs)	STOP contact active for MASTIER barrier (message shown on SLAVE controller displayed).
dAtA	Parameter I modified. Press the PROG key until RPP- appears on the display, then repeat the acquisition procedure

N.B. If one or more contacts are open, the barrier will neither open nor close.

If more than one safety device is in alarm state, once the problem relative to the first device is resolved, the alarm for the next device is displayed. Any further alarm states are also displayed with the same logic.

Press the TEST button again to exit test mode.

After 10 seconds with no user input, the display returns to command and safety device state display mode.

3.4 Standby mode



This mode is activated after 30 minutes with no user input. The POWER LED flashes slowly.

Press UP ▲, DOWN ▼, + or - to reactivate the control unit.





3.5 Travel acquisition

Before starting:

Select the length of the boom with the parameter A1



It is very important that this parameter is selected correctly. An incorrect setting may cause severe damage or injury.

SELECTION	MODEL	BOOM
A100	AG2 	up to 3 m
A101	AG2 	from 3 m to 4,5 m
A102	AG2 	from 4,5 to 6 m
A103	BK 	up to 3 m
A104	BK 	from 3 m to 4 m

- Select the position of the barrier in relation to the gate, using parameter 71. The factory setting of the parameter is with the barrier installed on the right (7101) and the boom opening/closure gate on the left (seen from the inspection hatch side).

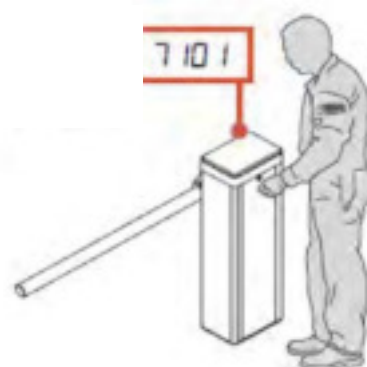

If the installation position is changed from the right to the left, the position of the spring(s) must also be changed. For the correct installation refer to the Quick set up mechanical manual provided with the equipment.

- Check that the "operator present" function is not enabled (A100).



3. Check the spring balance setting and the mechanical stop settings. See the Quick Set up installation manual for AG2 and BK Barrier. $<60^\circ$

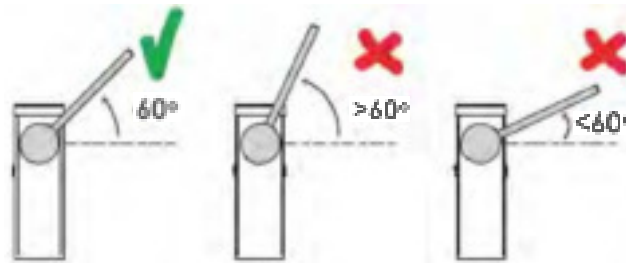

4. For installations with opposed barriers, connect the command signals and safety devices to the MASTER controller. (see fig 18).

5. Move the boom pole to the completely CLOSED position.

6. Press TEST (see TEST mode 3.3) and check the command signal and safety device states. If the safety devices are not installed, jumper the contact or disable safety device function from the relative parameter (50, 51 and 73).

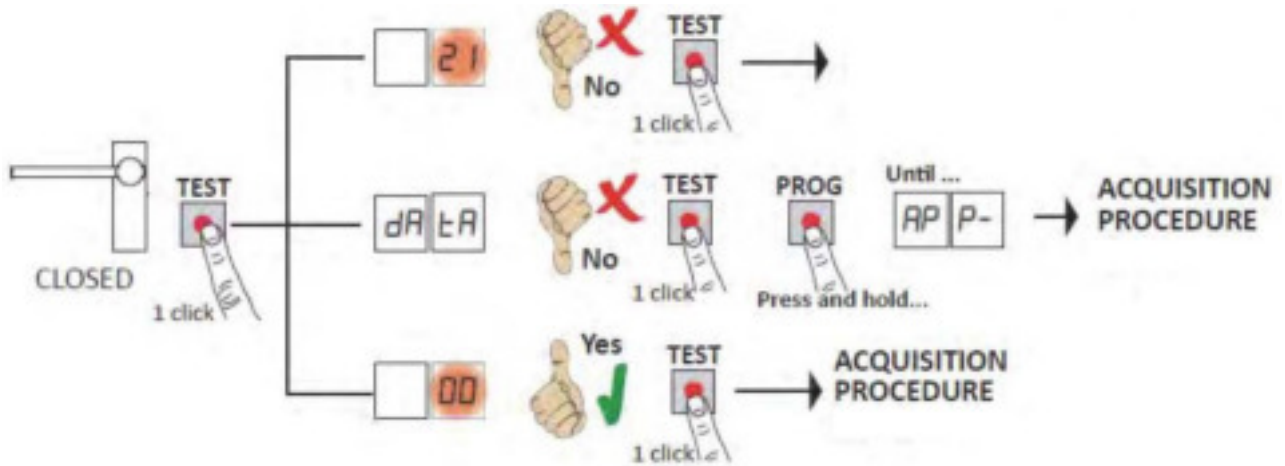

7. Acquisition procedure

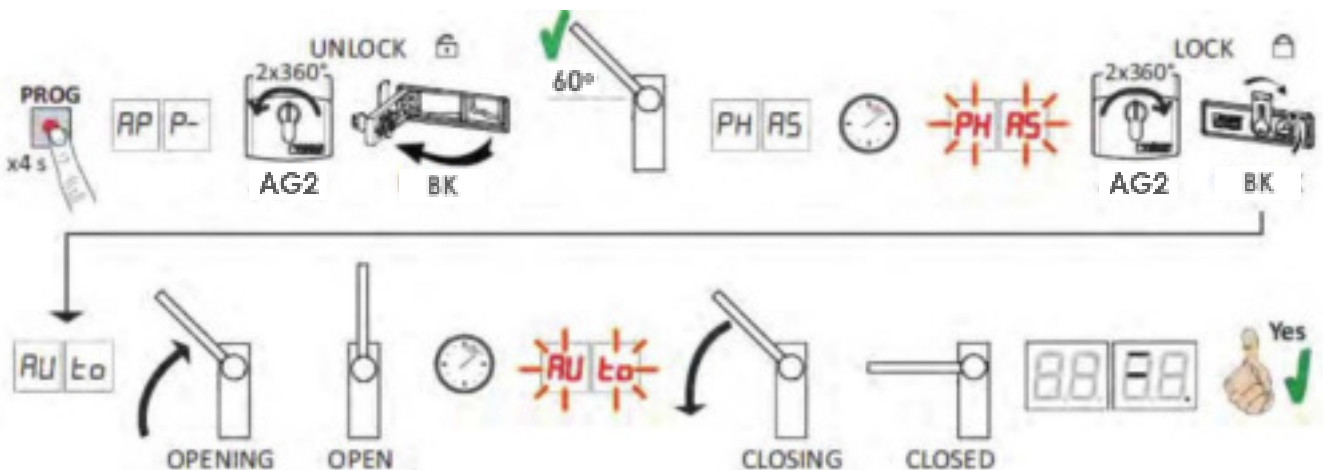

- Press and hold PROG for 4 seconds. RP P- is shown on the display.
- Unlock the boom gate.
 - **AG2:** Turn the key anticlockwise by two full turns.
 - **BK:** Open the release cover.

- The barrier goes to 60° degree.
- After a few seconds, the message PH A5 is shown on the display. The controller unit launches a calibration procedure. The operating parameters of the motor are determined during calibration.
- If the motor calibration procedure is successful, the message PH A5 flashes on the display.
- To lock the barrier again
 - **AG2:** Turn the key clockwise by two full turns.
 - **BK:** Close the release cover and turn the key.
- The acquisition procedure now starts. The message AUto is shown on the display and the boom gate starts opening at low speed.
- Once the boom gate mechanical stop is reached, the boom gate stops briefly. The message AUto flashes on the display.
- The boom gate closes until it reaches the closed mechanical stop.
- If the acquisition procedure is completed successfully, the display enters the command and safety device state display mode .
- If the following error messages are shown on the display, repeat the acquisition procedure:
 - no PH: calibration procedure failed.
 - AP P.E: acquisition error.

4. Selection of the Boom Gate Installation Position

- AG boom gates are supplied as standard DX handing (see Fig 9).
- For non standard SX installation you need to unlock the boom gate and remove the spring.
- Before removing the spring, make a note of the holes that the spring is fitted to as they will be the same holes on the non standard side.
- Move the spring arm to the non standard SX position as shown in (Fig 9).
- Lock the boom gate.

The key release mechanism does not need to be changed when changing the handing.

For non standard SX handing parameter 71 needs to be changed from 01 to 00 so that the controls know the boom handing.

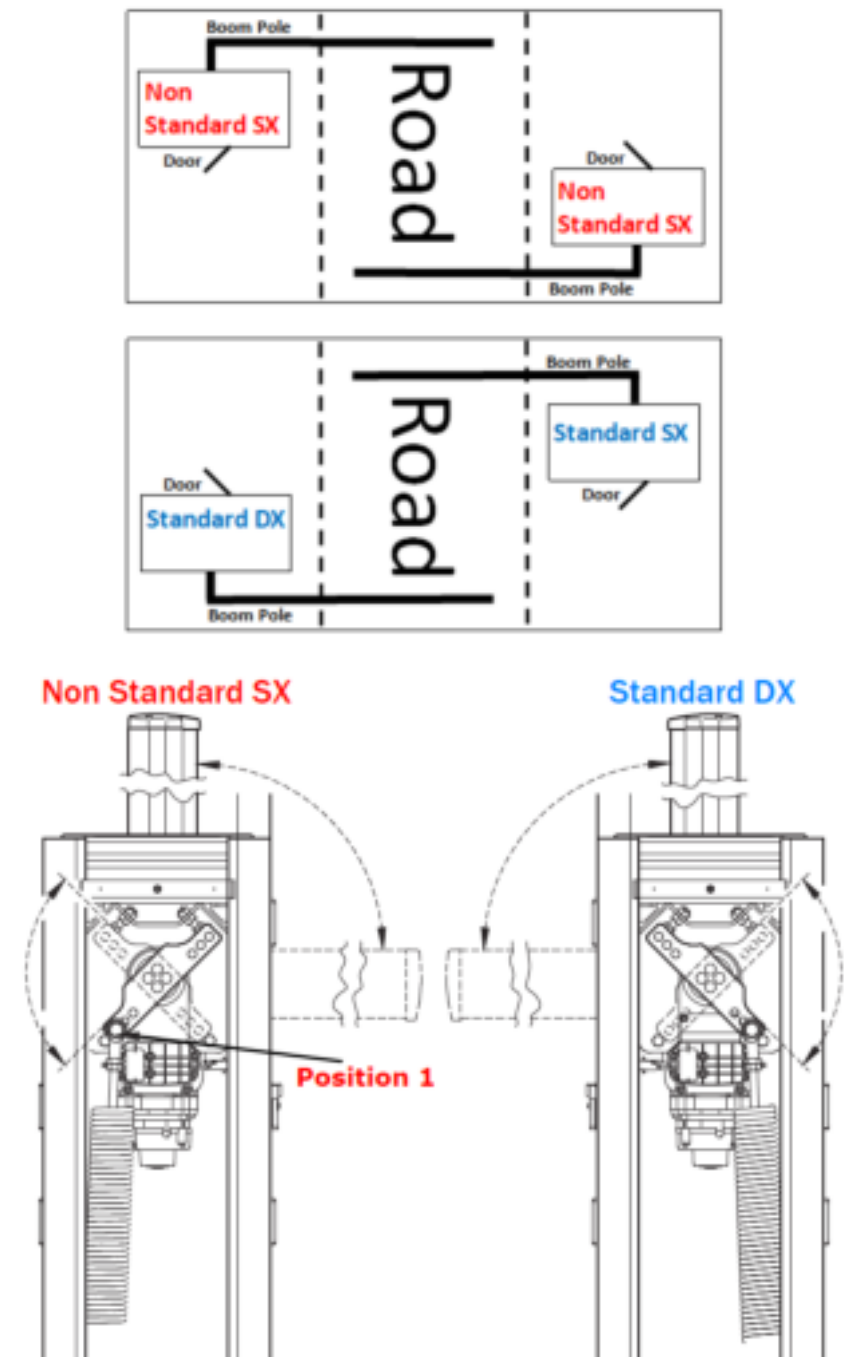

5. Examples of applications in parking access mode

The BK controller manages the system in parking access mode. This function is enabled with parameter B3.

N.B: the input FT cannot be disabled in the following operating situations. If the contact (NC) is opened during a closing manoeuvre, the barrier reopens and remains open until the contact is closed again.

The automatic closing time is enabled if parameter 21 is different to 00. Adjust an automatic closing time that allows the vehicle to complete the crossing.

Bi-directional mode with immediate closure (830 I)

When entering and leaving the parking area, the barrier is opened with an APOpen command (terminal block).

Once the vehicle has crossed the barrier and released contact **FT**(NC) (e.g. from magnetic loop), the barrier closes immediately. When parameter 21=00, the barrier open and remains open until the vehicle has completed the passage. If the vehicle moves back, the barrier remains open.

NOTE: it is possible to add further 5 s delay before closing, setting A 5 99.

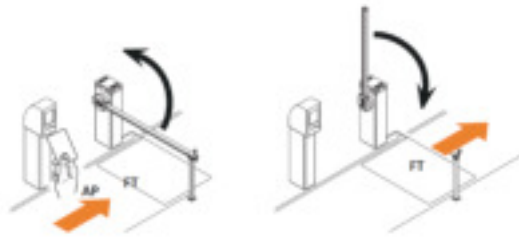

Directional mode 1 (83 02)

When entering the parking area, the barrier is opened with an **AP** open command (terminal block).

Once the vehicle has crossed the barrier and released contacts **FT**(NC) and **PED** (NO), the barrier closes. When leaving the parking area, the barrier is opened by a **PED** command received from the magnetic loop.

Once the vehicle has crossed the barrier and released contact **FT**(NC), the barrier closes.

When parameter 21=00, the barrier open and remains open until the vehicle has completed the passage. If the vehicle moves back, the barrier remains open.

NOTE: it is possible to add further 5 s delay before closing, setting A 5 99.

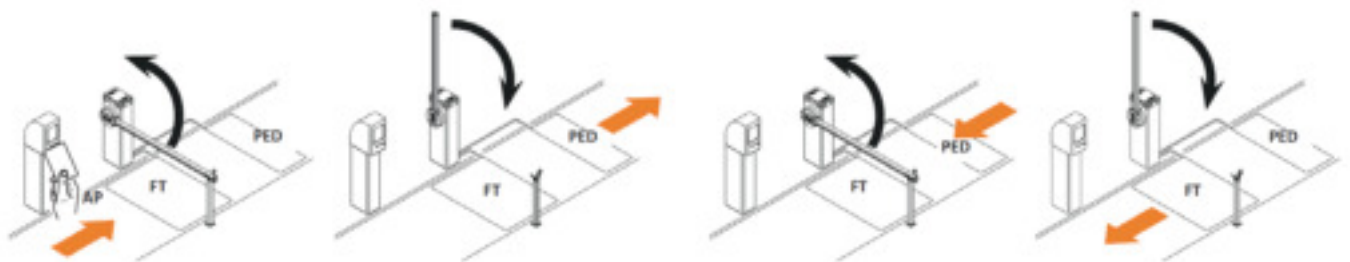

Directional mode 2 (83 03)

When entering, the barrier is opened with an **AP** open command (terminal block), and closes after the automatic closing time set with parameter 2 I

NOTE: in order to have the automatic closing, it is recommended to set parameter 2 I different to 00.

When leaving the parking area, the barrier is opened by a **PED** (NO) command received from the magnetic loop. Once the vehicle has crossed the barrier and released contact **FT** (NC), the barrier closes.

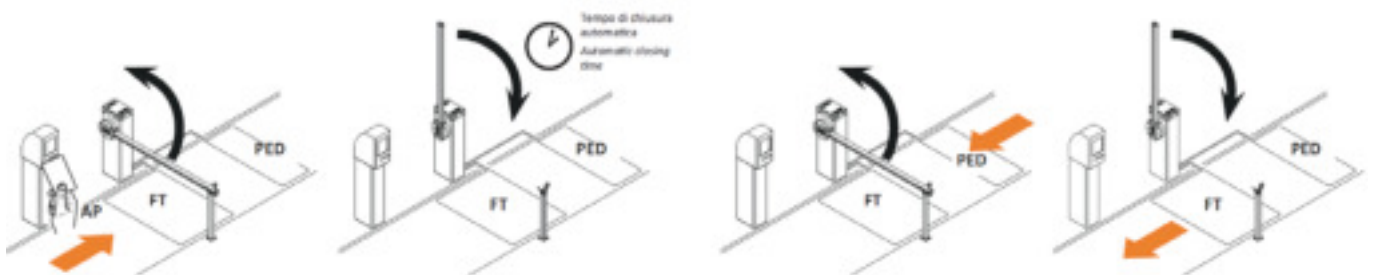

6. Index of parameters

PARAM.	FACTORY DEFAULT	DESCRIPTION
R0	00	Enable RS485 serial communication (MASTER-SLAVE)
R1	02	Barrier model and the length of the boom selection
R2	00	Automatic closing after time pause (from barrier completely open position)
R3	00	Automatic closing after mains power outage
R4	00	Step mode control function selection (PP)
R5	00	Pre-manoeuvre flashing warning
R6	00	Condominium function for partial open command (PED)
R7	00	Enable "operator present" function
R8	00	Barrier open/photocell test function and battery saving mode indicator lamp
10	00	Enable the AG/XP signal device to indicate barrier completely open/closed positions
11	10	Setting deceleration during opening
12	10	Setting deceleration during closure
21	30	Setting automatic closing time
29	00	Enable electric lock
31	09	Obstacle detection time setting (crush prevention)
33	10	Setting opening start acceleration
34	10	Setting closure start acceleration
40	04	Opening speed setting
41	04	Closure speed setting
42	01	Approach speed setting
43	15	Opening approach distance setting
44	30	Closing approach distance setting
49	01	Number of automatic closure attempts after activation of sensing edge or obstacle detection (crush protection)
50	00	Photocell mode for barrier opening (FT)
51	02	Photocell mode for barrier closure (FT)
52	01	Photocell (FT) mode with barrier closed
56	00	Enable close command 6 s after activation of photocell (FT)
65	08	Motor stop distance setting
71	01	Installation position of barrier relative to gateway (seen from the inspection hatch side).
73	00	Sensing edge COS configuration
76	00	Radio channel 1 configuration (PR1)
77	03	Radio channel 2 configuration (PR2)
78	02	Flashing light / upper cover lights frequency configuration
79	00	Operating mode of signal lights on boom
80	00	Clock contact configuration

PARAM.	FACTORY DEFAULT	DESCRIPTION
B 1	00	Enable safeguarded barrier closure
B2	03	Safeguarded closure activation time setting
B3	00	Parking access mode selection
B4	00	Enable close command after photocell activation (FT)
B5	00	Enable automatic open function with flat battery
90	00	Restoring factory default values
n0	01	HW version
n1	23	Year of manufacture
n2	45	Week of manufacture
n3	67	Serial number
n4	89	
n5	01	
n6	23	FW version
n7	45	RS485 serial communication version
o0	01	Manoeuvres performed
o1	23	
o1	45	
h0	01	Manoeuvre hours
h1	23	
d0	01	Days with unit switched on
d1	23	
P1	00	Password
P2	00	
P3	00	
P4	00	
CP	00	Password change protection

7. Diagrams

Control Panel AG2 and BK

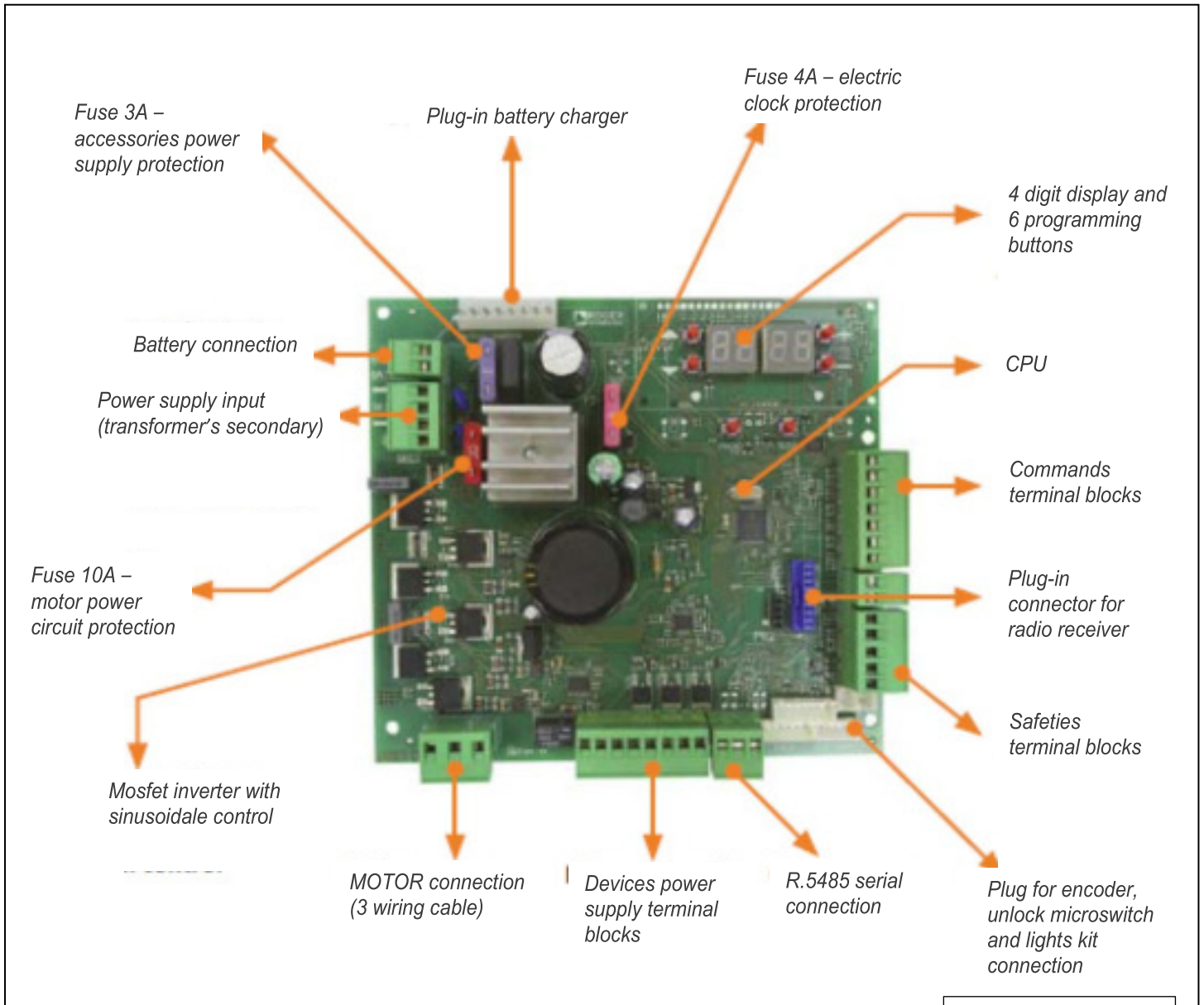

Firmware Rev r3.45

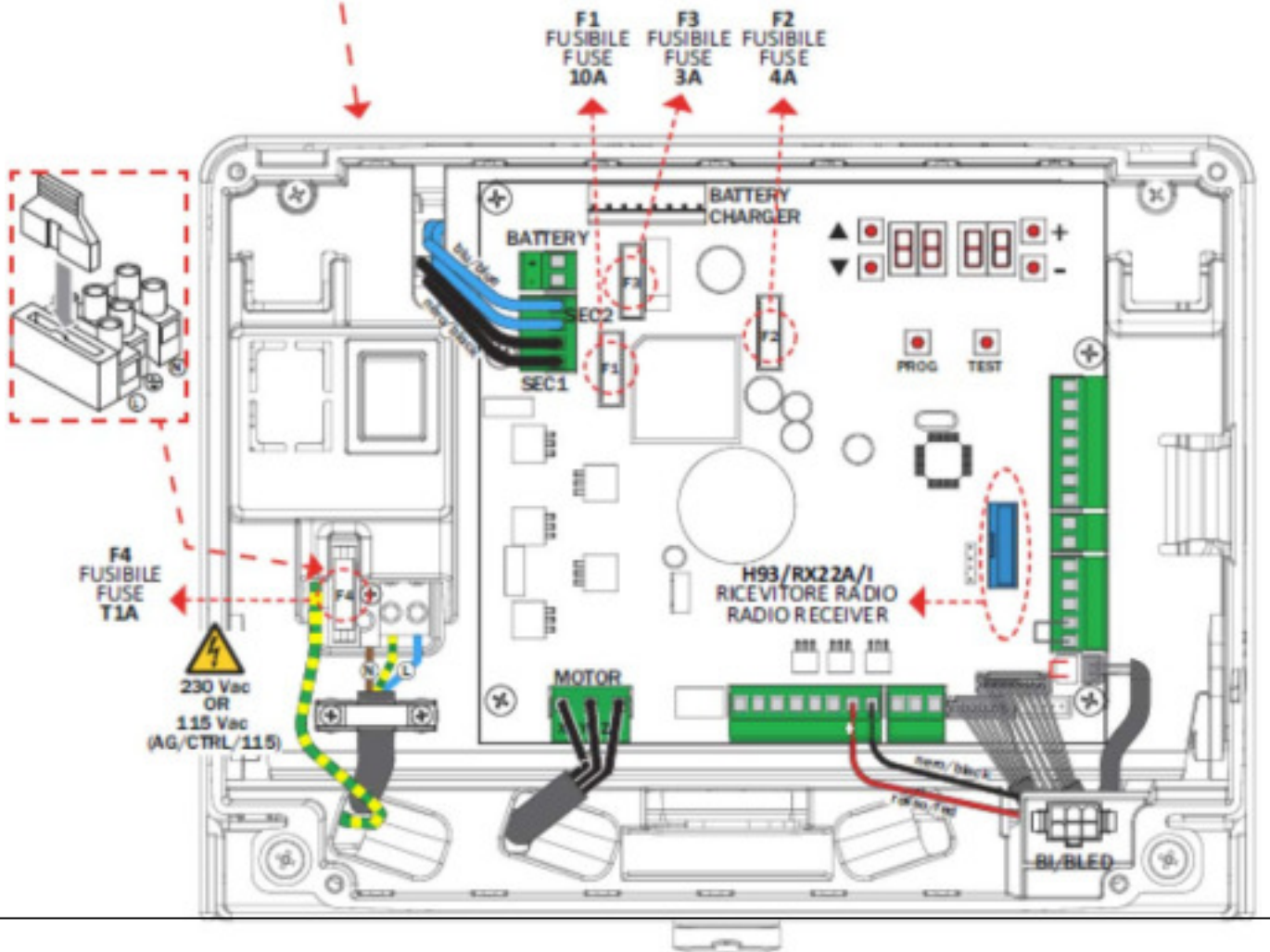
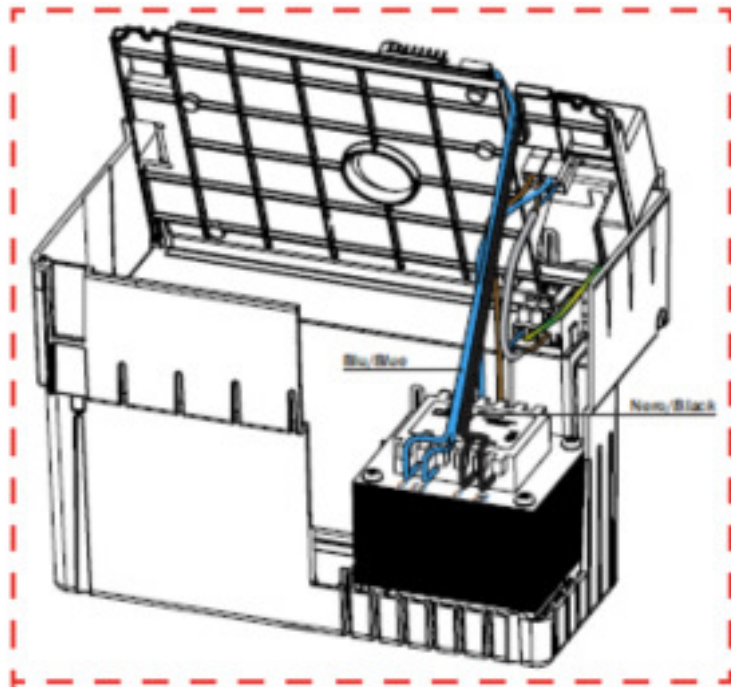

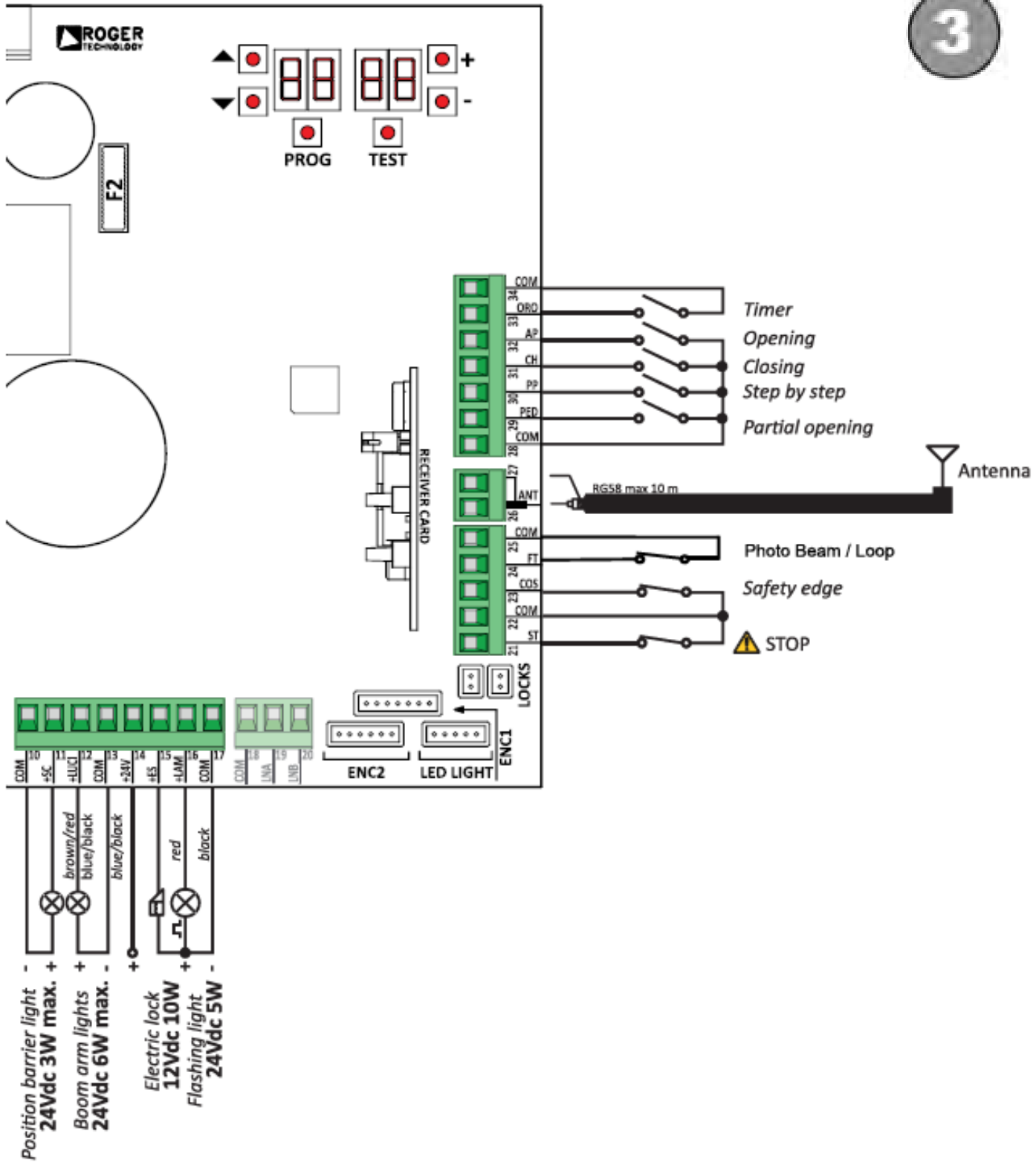

Position barrier light
24Vdc 3W max.

Boom arm lights
24Vdc 6W max.

Electric lock
12Vdc 10W

Flashing light
24Vdc 5W

Timer
Opening
Closing
Step by step
Partial opening

Photo Beam / Loop
Safety edge
STOP

Antenna

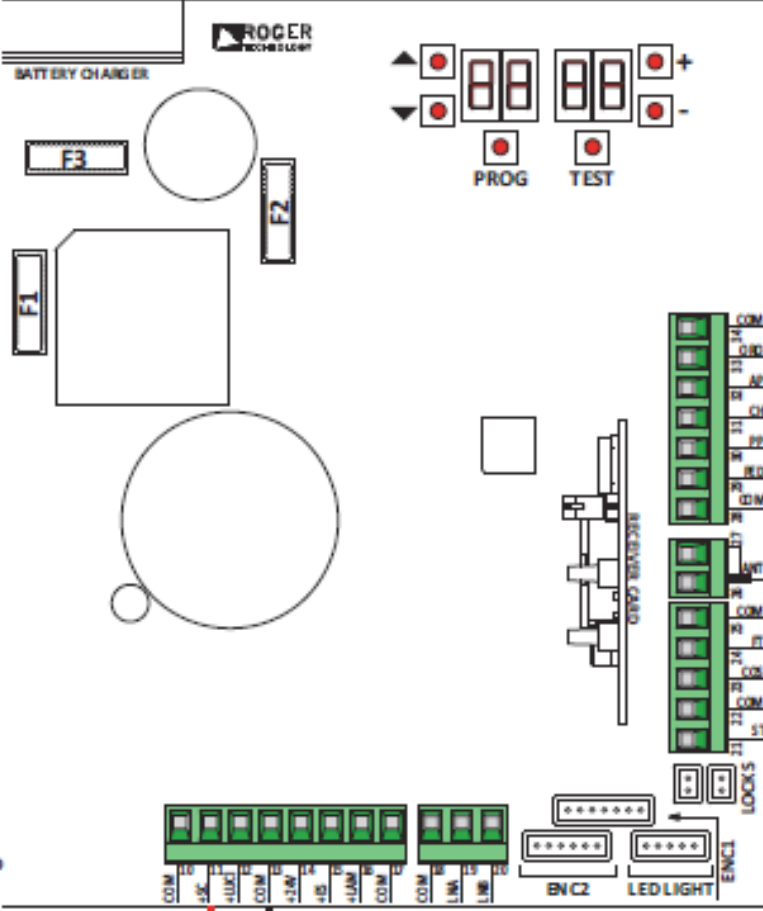
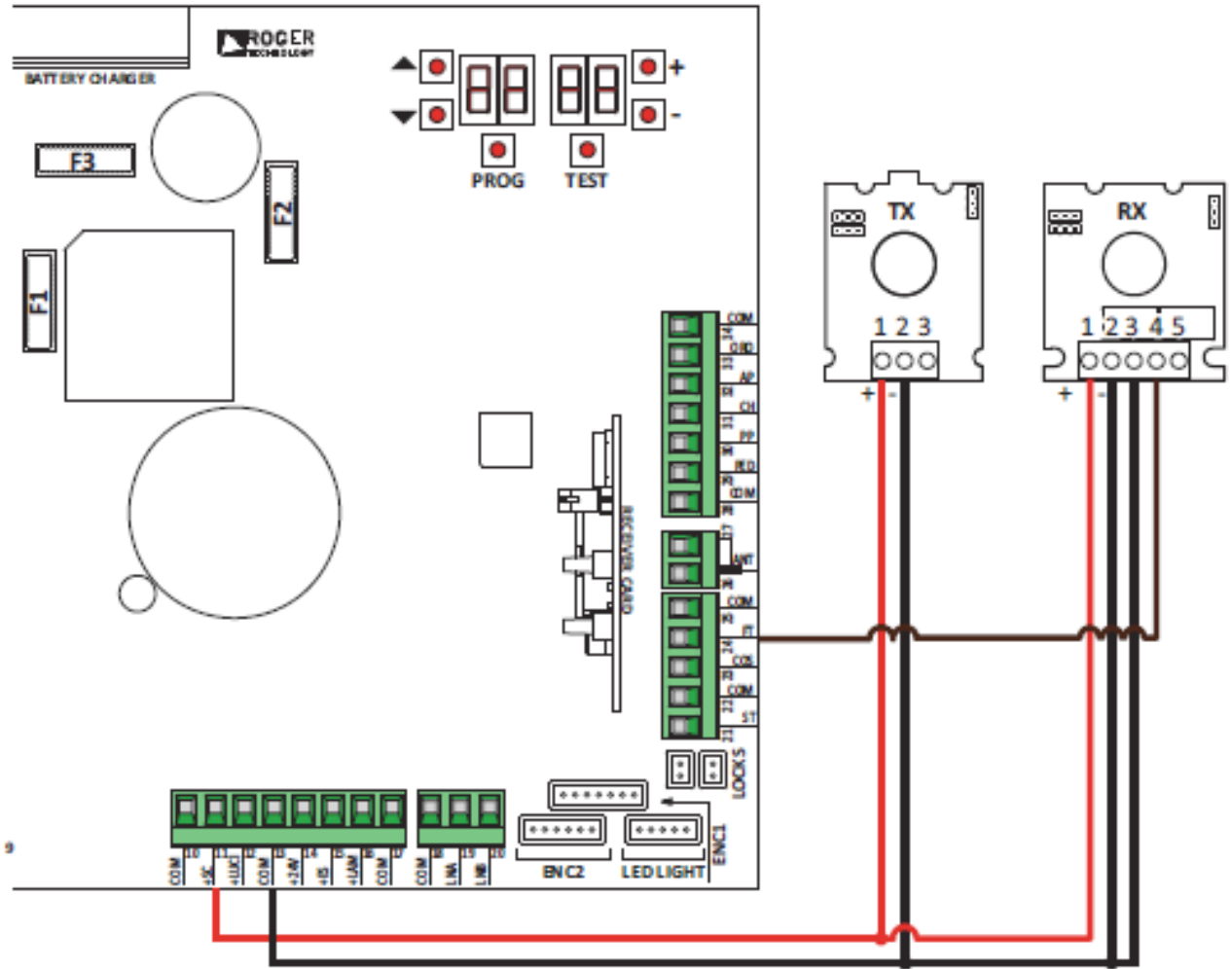

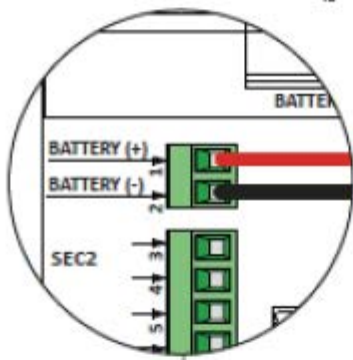
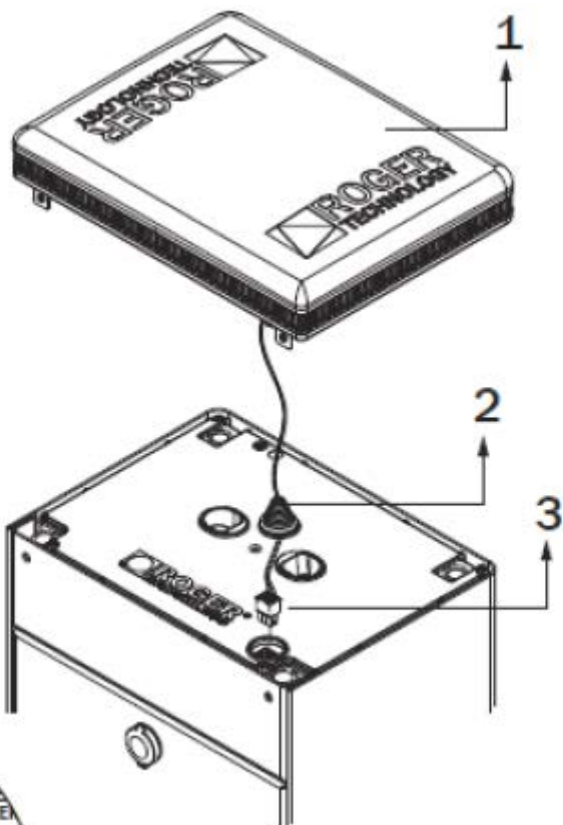

RED ⊕
BLACK ⊖

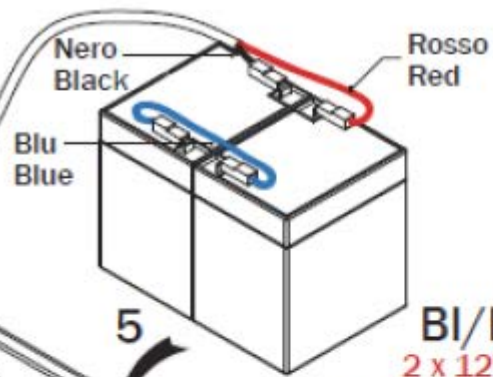

BI/BAT/KIT
2 x 12V 4500 mAh
AGM Battery ONLY

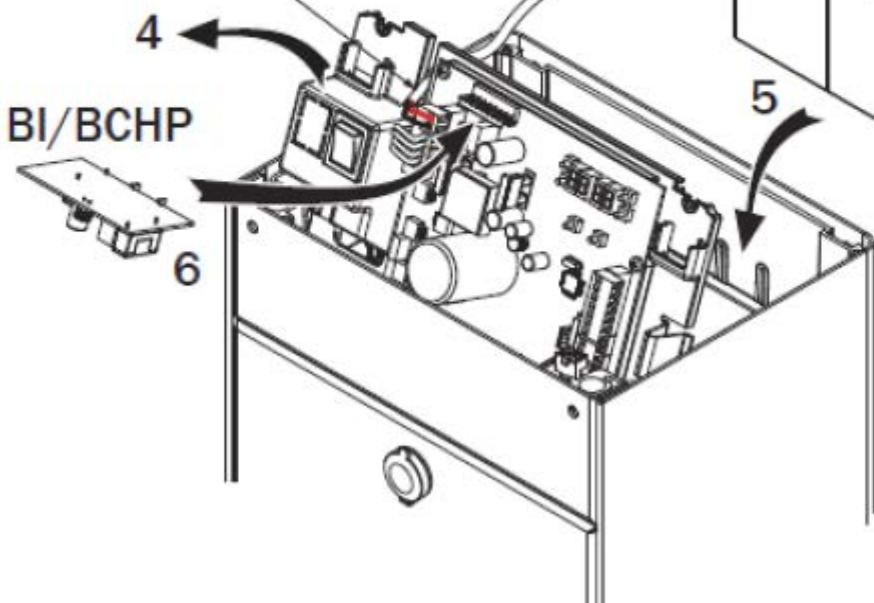

8. Commands and Accessories



If not installed, safety devices with NC contacts must be jumpered at the COM terminals or disabled by modifying the parameters **50,51** and **73**.

For installation with two opposed barriers, connections for command signals and accessories must be made on the MASTER controller. The sensing edge and, if used the STOP command signal must be connected to the SLAVE controller.

KEY: N.A. (Normally Open) | N.C. (Normally Closed)

Contact	Description
11(+5C) 10(COM) 	Barrier open/closed indicator lamp 24 V DC 3 W. The function of the indicator lamp is determined by the parameter AB.
11(5C) 13(COM)	Photo cell test function and/ or battery saving mode connection (fig. 6). The power feed for the photo cell transmitters (TX) may be connected to terminal 11(5C). Set the parameter AB 02 to enable the test function. Each time a command is received, the controller unit switches the photo cells off and on to check that the contact changes state correctly. Power feeds for all external devices (excluding the external radio receiver) may be connected to reduce battery consumption (if batteries are used). Set AB 03 or AB 04. In the case of installations with two opposed barriers, the functions are not available for the SLAVE barrier. WARNING! If contact 11(5C) is used for the photo cell test function or battery saving function, a barrier open indicator lamp cannot be connected.
12(LIGHTS) 13 (COM) 	Input for connecting AG/ALED series signal lights on boom (optional). 24 V DC 12W max.
14(+24V) 13(COM)	Power feed for external devices, max. 10W. See technical specifications.
15(+ES) 17(COM) 	Input for connecting electric lock. See technical specifications.
16(+LAM) 17(COM) 	Connection for flashing light (24 V DC - max. 5 W). The settings for the pre-maneuver flashing warning signal may be selected with parameter A5, while the flashing mode is set with parameter 78.

18(COM)-19(INA)-20(LNB)

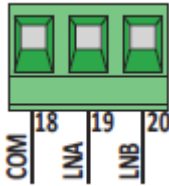

RS485 serial communication cable connection (3 x 0.5 mm- max. length 20 m) for installation of two MASTER / SLAVE opposing barriers (from firmware version 06 13 or later).

Connections

Connect the **COM-INA-LNB** terminals of the MASTER barrier to the relative terminals of the SLAVE barrier.

The MASTER barrier is the barrier which opens completely when the partial open command (PED) is received.

Set parameter AO 11 for the MASTER barrier and parameter AO 10 for the SLAVE barrier.

All command signals, the photocells and the main STOP command must be connected to the MASTER barrier. Sensing edges must be connected to the respective barriers.

An auxiliary STOP command signal may also be connected to the SLAVE barrier. If not used, jumper terminals 21 (SD)-22 (COM) on the SLAVE controller.

All parameters except for AO and 73 must be set on the MASTER controller.

The travel acquisition procedure must be performed for both barriers, after setting the parameters as required and in accordance with the type of installation.

Alarm messages are viewable on the displays of the respective controllers.

18(COM)-19(INA)-20(LNB)

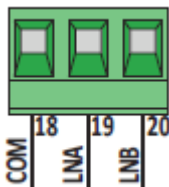

Function



Serial communication enables synchronised operation of the two barriers.





The obstacle detection system immediately reverses the direction of the boom which detected the obstacle, while the other boom reverses after a fixed delay.

If the MASTER barrier is completely open or completely closed and the SLAVE barrier is in an intermediate position, the MASTER barrier sends a re-alignment command to the SLAVE barrier, with a 5 second pre-maneuver flashing warning signal.

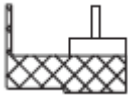
Conversely, if the MASTER barrier is an intermediate position, after 5 seconds of inactivity, it re-aligns with the SLAVE barrier.

The alignment function is disabled if the "operator present" function A7 01 is enabled.

<p>21(ST) 22(COM)</p> 	<p>STOP command input (NC).</p> <p>The current maneuver is arrested if the safety contact opens.</p> <p>N.B.: the controller is supplied with this contact already jumpered by ROGER TECHNOLOGY.</p> <p>In the case of installations with two opposed barriers, if the STOP command signal is given for the MASTER barrier, both barriers stop. If the STOP command signal is given for the SLAVE barrier, only the SLAVE barrier stops.</p>
<p>23(COS) 22(COM)</p> 	<p>Input (NC or 8.2 kOhm) for connecting sensing edge COS.</p> <p>Movement is reversed (open) if the sensing edge is activated during closure.</p> <p>If the sensing edge is not installed, jumper the terminals 23(COS)-22(COM) or set parameter 1300.</p> <p>In the case of installations with two opposed barriers, the sensing edge (if installed) must be connected to and configured for both the MASTER barrier and the SLAVE barrier.</p>
<p>24(FT) 13(COM)</p> 	<p>Input (NC) for connecting photo cell FT (fig. 6)</p> <p>The photo cells are configured by default with the following settings:</p> <ul style="list-style-type: none"> - 50 00 . Photo cell triggers only during barrier closure. Photo cell is ignored during barrier opening maneuver. - 5 102 . Movement is reversed if the photo cell is triggered during barrier closure. - 52 0 1 . The boom gate opens when an open command is received if the photo cell FT is obstructed. <p>If the photo cells are not installed, jumper the terminals 24(FT)-25(COM) or set the parameters 50 00 and 5 100.</p> <p>In the case of installations with two opposed barriers, the photo cells must be connected to and configured for the MASTER barrier only.</p> <p>In the case of installations with parking mode, the input FT may be used to receive a closing command from a magnetic loop (NC)</p>
<p>27 26(ANT)</p> 	<p>Antenna connector for slot-in radio receiver board.</p> <p>Use RG58 if an external antenna is used - maximum recommended length: 10 m.</p> <p>N.B.: do not make joints in cable.</p>

<p>29(PED) 28(COM)</p> 	<p>Partial open command input (NO).</p> <p>The barrier is always opened completely when the contact is closed.</p> <p>In the case of installations with two opposed barriers, the command PED only opens the MASTER barrier when both barriers are completely closed.</p> <p>In the case of installations with "Directional" parking mode (parameter 83 02 or 83 03), the input PED may be used to receive a closing command from a magnetic loop (NC)</p>
<p>30(PP) 28(COM)</p> 	<p>Step mode command input (NO).</p> <p>The function of this command is determined by parameter A4.</p>
<p>31(CH) 28(COM)</p> 	<p>Close command input (NO).</p>
<p>32(AP) 28(COM)</p> 	<p>Open command input (NO).</p>
<p>33(ORO) 34(COM)</p> 	<p>Clock timer contact input (N.O.).</p> <p>When the clock function is active, the barrier opens and remains open.</p> <p>At the end of the programmed time set with the external device (clock) the barrier closes.</p>
<p>ENC 1</p>	<p>7-way connector for connecting to encoder installed on motor</p> <p>WARNING! Always disconnect from electrical power before disconnecting or connecting the encoder cable.</p>
<p>ENC 2</p>	<p>6-way connector for connecting to encoder installed on one side of motor</p> <p>WARNING! Always disconnect from electrical power before disconnecting or connecting the encoder cable.</p>
<p>LED LIGHT</p>	<p>Connector for the (OPTIONAL) AG/EXP signal device connection and flashing lights installed on the top cover</p>
<p>LOCKS</p>	<p>Connectors for connecting lock device micro switch and safety stop micro switch on barrier inspection hatch Jumper the other connector if only one connector is connected.</p>

<p>RECEIVER CARD</p>	<p>Connector for slot-in radio receiver board. The controller has two radio remote control functions by default:</p> <p>PR1 - step mode command (modifiable with parameter 76).</p> <p>PR2 - close command (modifiable with parameter 77).</p>
<p>B71/BCHP BI/BCHP BATTERY CHARGER</p> <p>AG/BATKIT BI/BATKIT BATTERY KIT 2x12 Vdc 4.5 Ah (AGM type ONLY)</p>	<p>Connector for slot-in battery charger board.</p> <p>In the event of a mains power loss, the controller unit is powered by the batteries. When battery power is used, the message bAtt is shown on the display and the flashing light flashes briefly at intervals until mains power is restored or until the battery voltage drops below the minimum permissible limit. In this case, btLO (Battery Low) is shown on the display and the controller unit accepts no commands.</p> <p>If mains power is lost while the boom is moving, the boom stops and then automatically resumes the interrupted maneuver after 2 seconds.</p> <p>Setting a value for parameter 85 other than 00 enables automatic opening when the battery voltage drops below the safety limit. Once the boom reaches the completely open position, the boom remains open and the controller accepts no further commands until mains voltage is restored.</p> <p>In the case of installations with two opposed barriers, the battery charger must be connected to both barriers.</p> <p>Parameter 85 is not available for SLAVE automation systems.</p> <p>WARNING! The batteries must always be connected to the electronic controller unit in order to charge. Periodically (at least every 6 months), check that the batteries are in good working order.</p> <p>For more information, refer to the installation manual for the B71/BCHP or BI/BCHP battery charger.</p>