



Vehicle Access Control
Pedestrian Access Control
Safety & Security Equipment

T +61 7 3205 1123

www.rotech.com.au

e: info@rotech.com.au

BIO NIK BK AUTOMATIC BOOM GATE

Mechanical Quick Set-Up Instructions (V1219)



NOTE: The Quick Set-Up Mechanical Installation Instructions below provide basic information for setting up the Bionik BK Automatic Boom Gate.

For more detailed installation information please refer to the full set up instructions document.

QUICK SET-UP MECHANICAL INSTALLATION

The following quick set-up instructions are modified extracts from various sections of the original Mechanical Installation Instructions. They explain the installation procedure using local terminology.

Topics covered:

1. Installing the boom gate cabinet
2. Unlocking the mechanism
3. Set up the handing
4. Fitting the boom pole
5. Moving the spring to change the handing
6. Fitting the red decals

In Australia the boom gates are supplied with the spring and cabinet LEDs fitted.

All the new design boom gates from Roger are now described as Bionik but in Australia we will keep the old designations to prevent confusion. In the Roger manuals the AG2 is shown as Bionik type KB followed by the size 004 or 006. The new small footprint Bionik is shown as BI followed by the size 003, 004.

When the boom gate is fixed and the pole fitted the auto learn function can be started. [SEE ELECTRICAL SET-UP INSTRUCTIONS](#)

1. CABINET INSTALLATION

1.1 Preliminary checks

- Check that the site chosen for installation meets the overall space requirements of the product and that there are no obstacles overhead pipes / signs etc.
- Check the dimensions of the concrete base are the same as shown in Fig 1 (this is the minimum requirement). The base must be flat and level.

1.2 Installing on existing base

- Place the base plate in the center of the concrete and trace the positions of the bolt holes. Drill the surface and fit 4 expansion anchor bolts. Minimum M12 x 75 mm

1.2.1 Installing on a new base

The illustrations here in are indicative only. The space necessary the boom gate and the accessories may vary depending on the site

The minimum requirement for the base is 1000mm x 1000mm x 400mm concrete reinforced with steel mesh.

- Fasten the 4 anchor ties to the plate (**fig. 1**). **N.B.** the bottom nut must be tightened to the end of the thread on the screw so that the top of the thread is at least 40 mm above the base plate.
- Sink the base plate with the anchors in the centre of the foundation, so that the surface is flush with the concrete and perfectly level. The cable conduits must protrude by a few centimetres from the centre of the plate.

1.3 Installing the boom gate

The BK Boom Gates are supplied as Standard DX handing. (**fig 9**)

- Undo and remove the washers and nuts from the anchors on the base plate. (**fig 3**)
- Undo and remove the 4 screws fastening the top cover.
- Open the cabinet door, turning the key clockwise by 90° (**fig 4**)
- Lift the top cover and disconnect the earth cable from the connector lugs on the cabinet (**fig 5**)
- Place the cabinet on the plate. The anchors on the base plate must fit through the four slots. (**fig 6**)
- Fit the washers and nuts removed previously. Move the cabinet as necessary in the slots to adjust the position of the barrier correctly. Tighten the nuts securely.

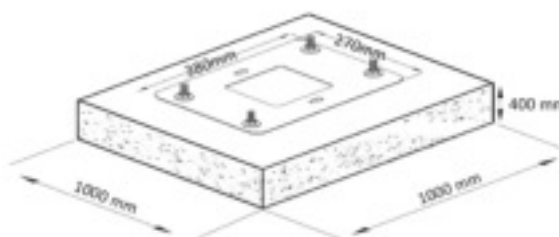
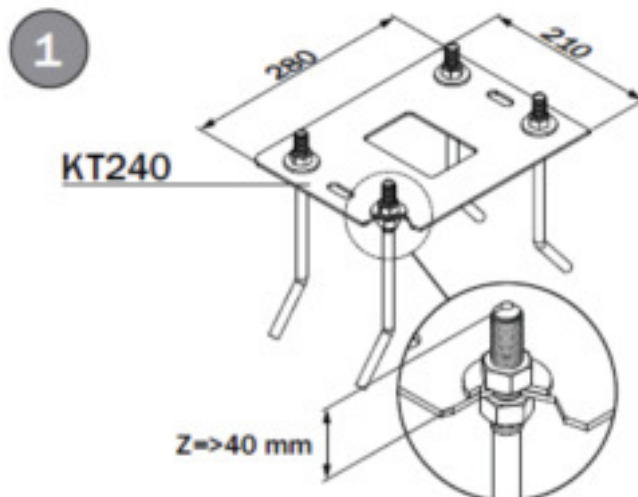

Minimum recommended dynabolts
M 12mm (dimension) x 75mm (length)

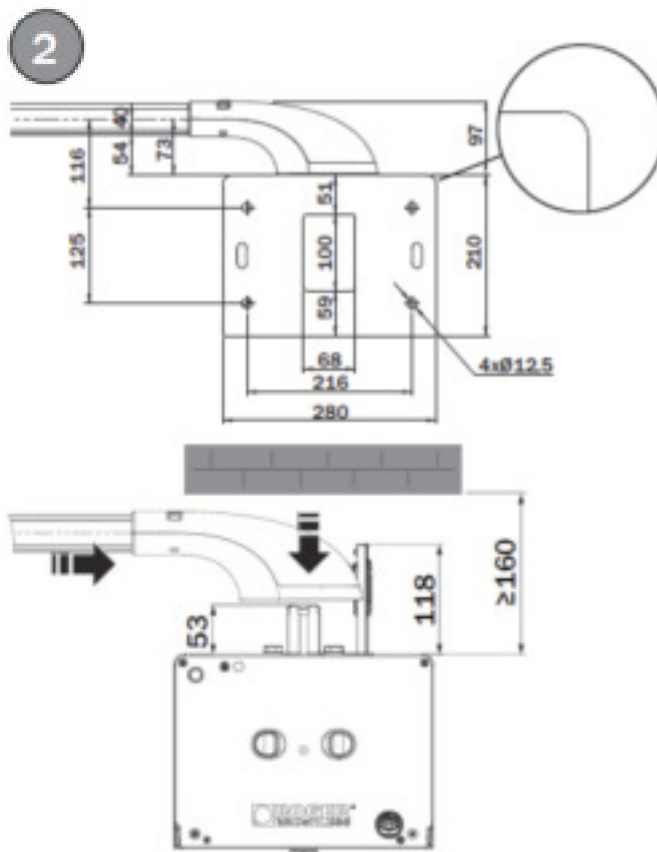

3

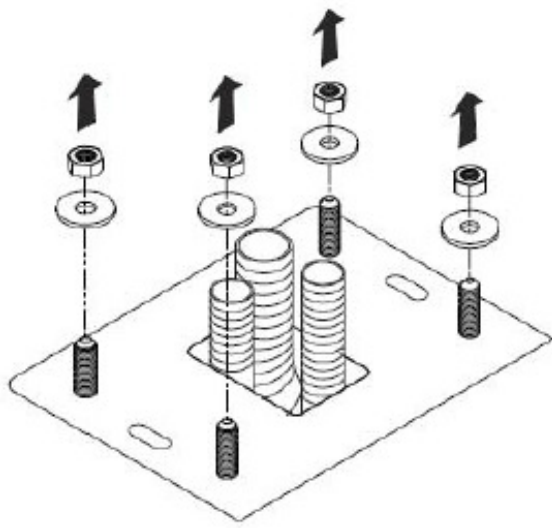

4

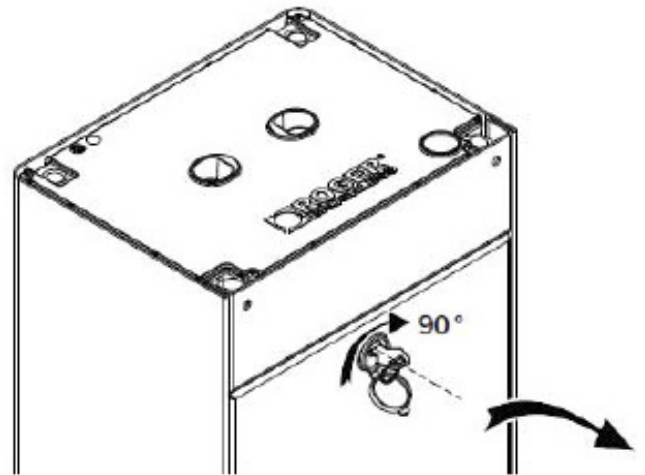

5

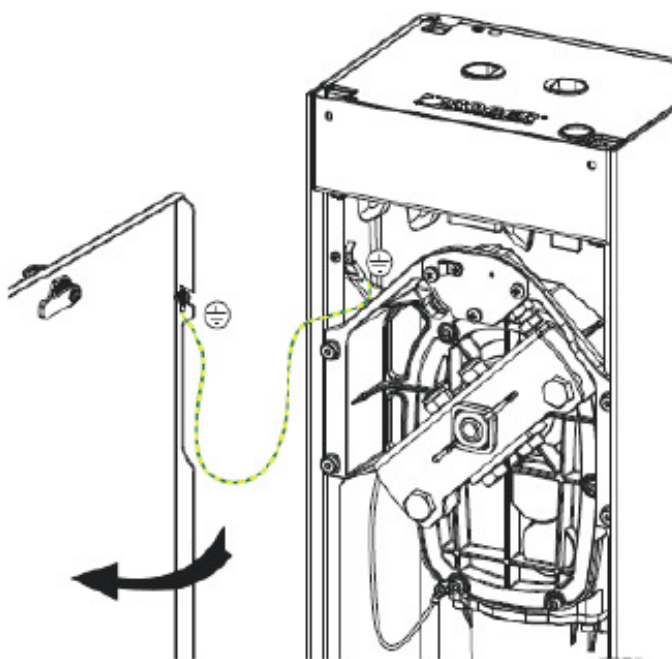

6

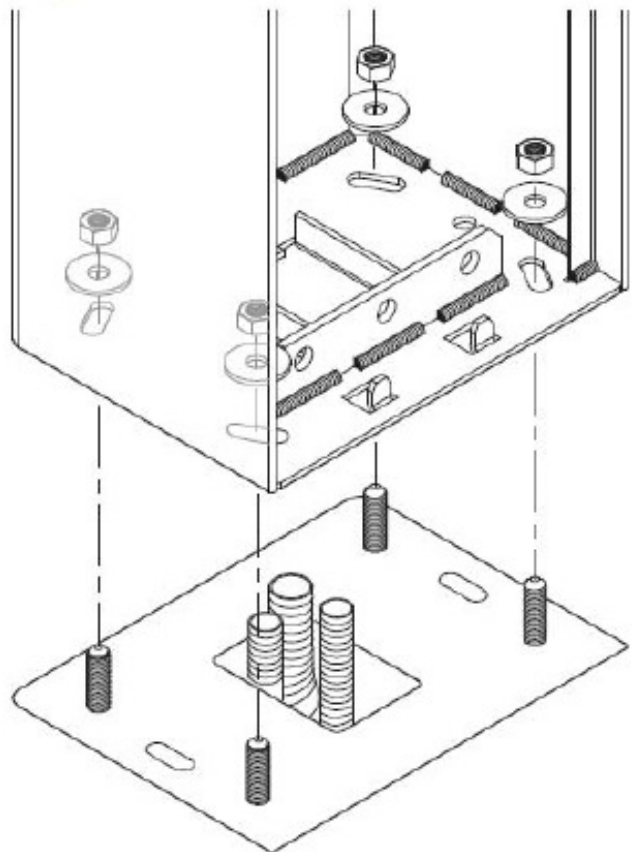

2 RELEASE AND LOCK PROCEDURE

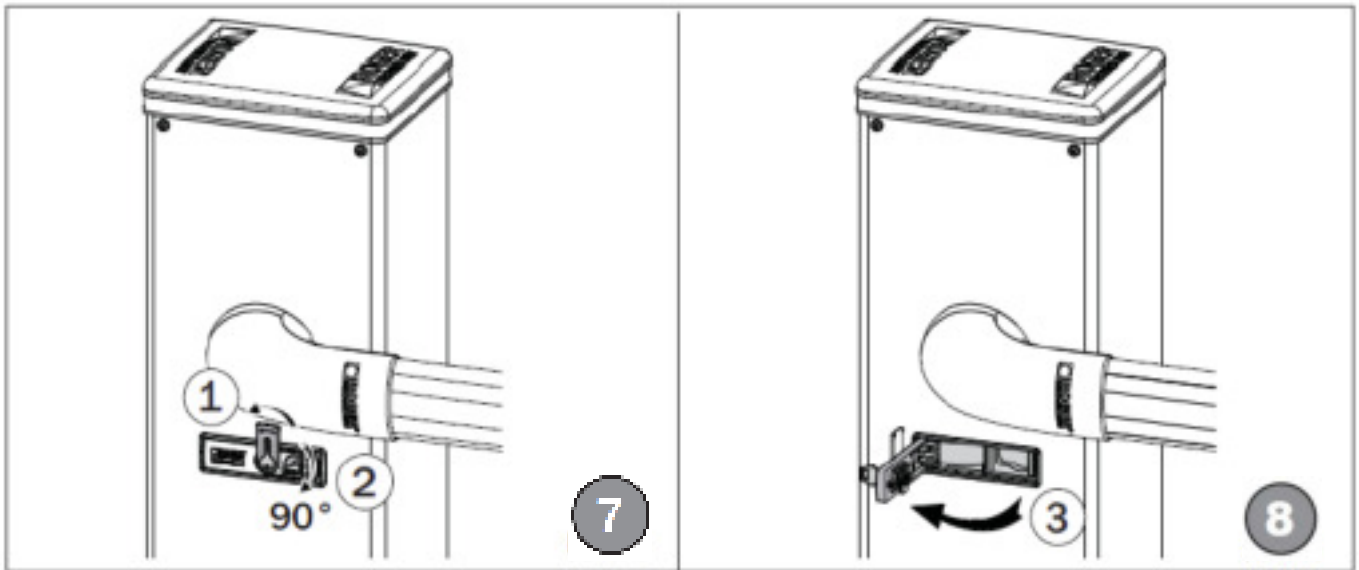

In some situations, such as in the event of a power outage or scheduled maintenance, it is necessary to release the drive mechanism.

RELEASE AND MANUAL OPERATION

- **Step 1:** Open the lock cover as shown
- **Step 2:** Insert the key into the lock and turn it clockwise by 90°
- **Step 3:** Pull the release arm towards you - this allows you to manually move the boom pole.

RESTORING AUTOMATIC OPERATION

To lock the barrier again, close release arm turn the key anticlockwise by 90°

Remove the key and close the lock cover.

NOTE If you do not fully rotate the key 90 the switch interlock will not engage which isolates the 240vac from the motor.

IMPORTANT: Frequent operation of the boom gate in manual mode with the mechanism released will damage the mechanism. If you need to disable the gate frequently please contact us.

3 BOOM GATE HANDING (fig 9)

BK boom gates are supplied as standard DX handing (see Fig 9).

- For non standard SX installation you need to unlock the boom gate and remove the spring.
- Before removing the spring, make a note of the holes that the spring is fitted to as they will be the same holes on the non standard SX side.
- Move the spring arm to the non standard SX position as shown in (Fig 9).
- Lock the boom gate.

The key release mechanism does not need to be changed when changing the handing.

For non standard SX handing parameter 71 needs to be changed from 01 to 00 so that the controls know the boom handing.

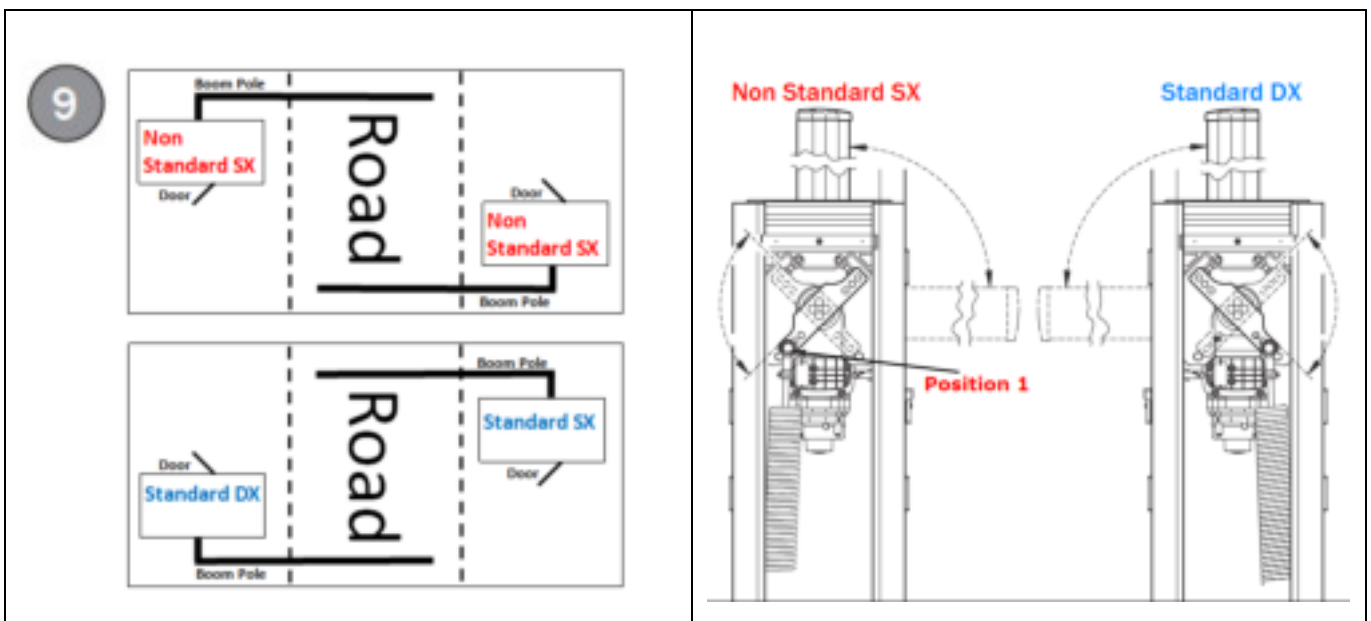

4 INSTALLING THE BOOM POLE (fig 10)

Disconnect the release mechanism and raise the pole to fully open, reconnect the mechanism so that the pole will be held in the open position.

- **IMPORTANT** Make sure the boom support arm (C) is in the vertical position and that the spring arm is in position (1).
- Insert the boom arm support (C) onto the drive shaft (D) make sure that there is only a 1 mm gap between the support arm and the cabinet as shown in (Fig 10)
- Attach the support arm using screws E1 E2 E3
- Fasten the rear cover (F) in position
- Pull the rubber profile (M) and the plastic cover strip forward 200 mm so that you can access the support fixing screws
- Insert the pole over the boom pole support and fasten with the 8mm x 20 bolts
- Reposition the rubber and plastic strip
- Fix end cap (G) and pole cover (A).

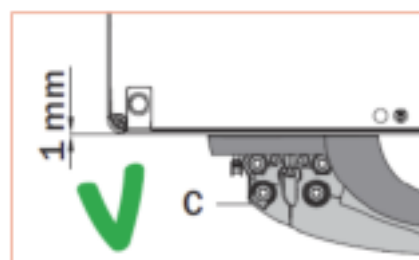
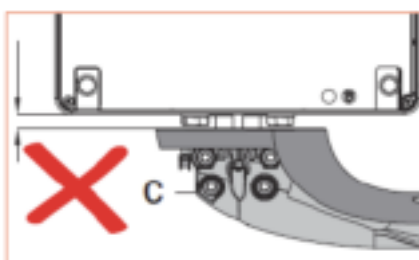
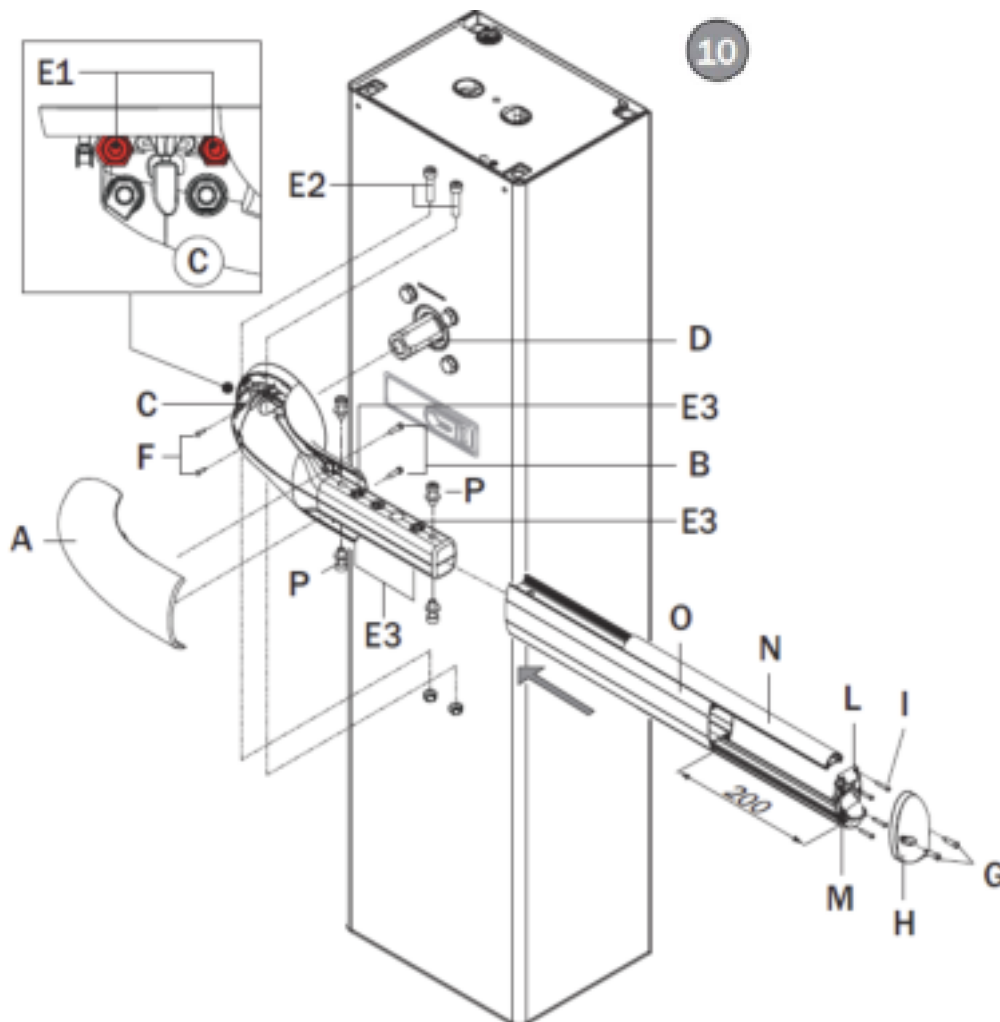

5 INSTALLING AND ADJUSTING THE SPRING

On all boom gates supplied in Australia the spring is already fitted but needs to be tensioned

- Unlock the barrier and move the boom into the fully open vertical position
- Lubricate the pivot points with lithium based grease (EP LITHO) (fig 11).
- Use the screws included to fasten the spring to the linkage lever (fig.12) on the correct side for the handing required.
- **IMPORTANT** For standard handing (DX) fit the bottom bolt into hole 1 and for non standard (SX) into hole 3
- Secure the springs to the bracket in the bottom of the cabinet (fig.13)
- To adjust the spring tension, loosen the nuts as indicated in (fig.14), then turn the spring clockwise to reduce the tension or anticlockwise to increase tension (fig 14).
- Lift the boom manually to an angle of 60° and adjust springs so that the pole is balanced in this position - then tighten the lock nuts.

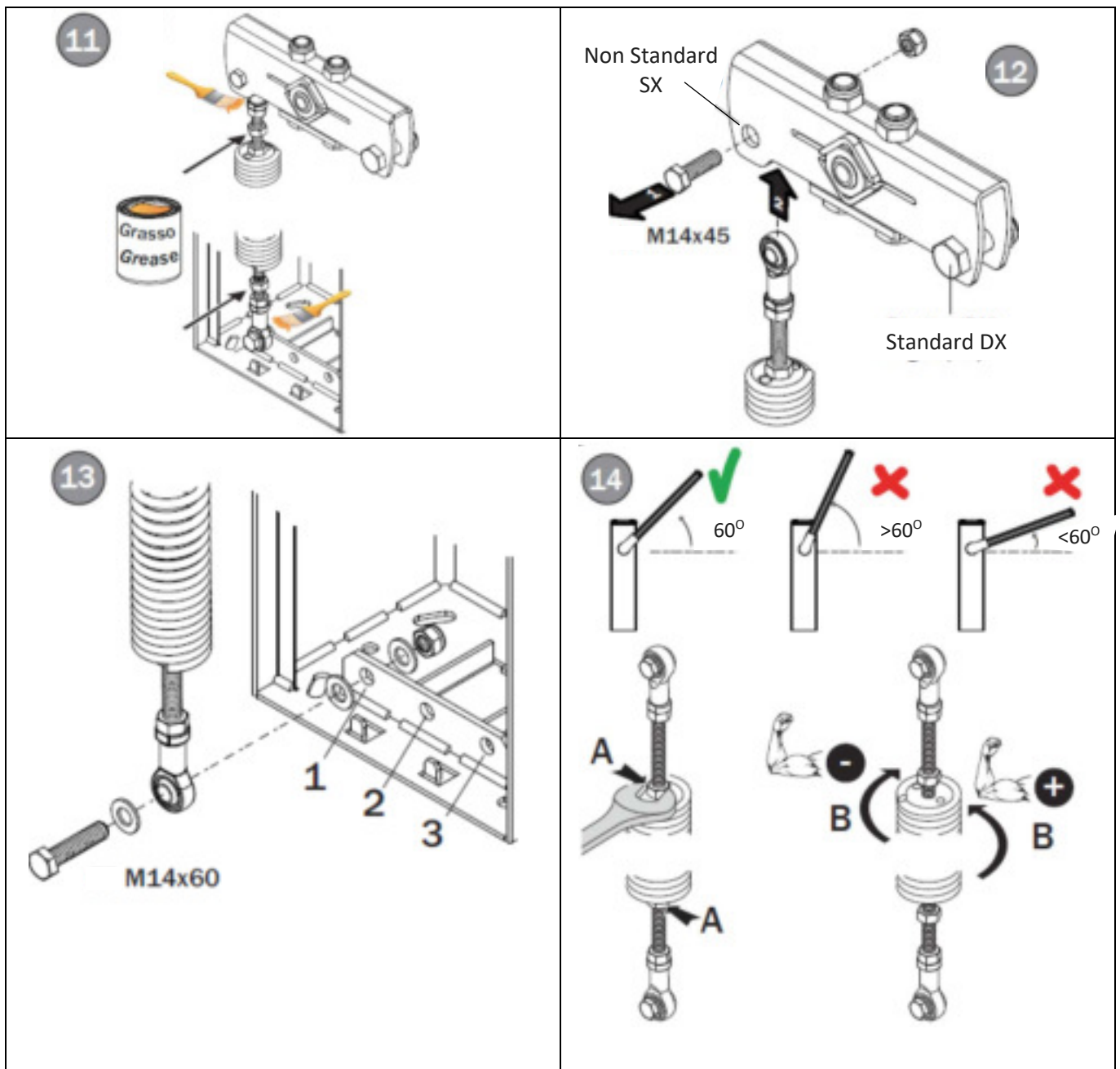

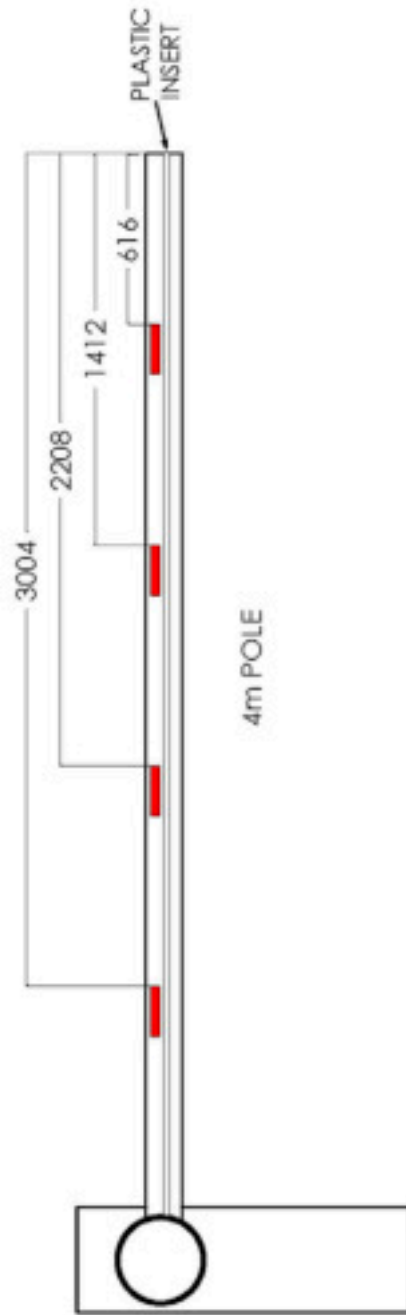
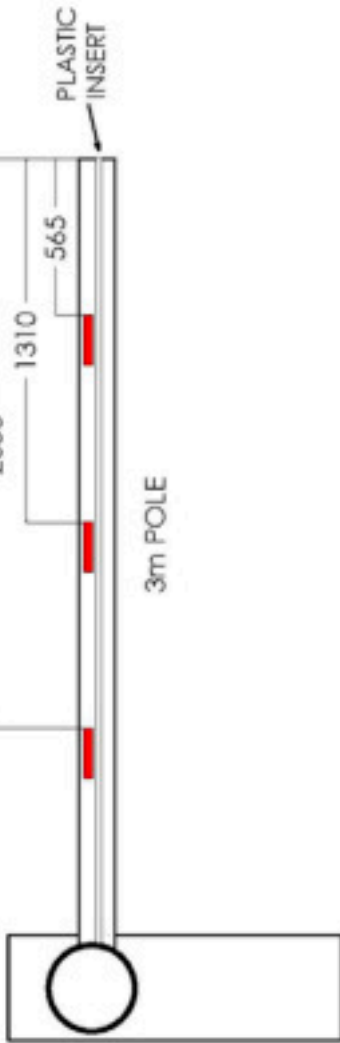

APPLICATION INSTRUCTIONS:

1. Apply 50 mm masking tape to the RED side of the decal to prevent the decal stretching
2. Remove backing from decal
3. Align the bottom edge of the decal with the top rib on the pole
4. From one edge press firmly and slowly move along the length of the decal to remove air pockets
5. Then remove masking tape
6. Do not attach decals to the plastic insert

Examples of applications in parking access mode

The BK controller manages the system in parking access mode.

This function is enabled with parameter B3.

N.B.: the input FT cannot be disabled in the following operating situations. If the contact (NC) is opened during a closing manoeuvre, the barrier reopens and remains open until the contact is closed again.

The automatic closing time is enabled if parameter 21 is different to 00. Adjust an automatic closing time that allows the vehicle to complete the crossing.

Bi-directional mode with immediate closure (83 0 1)

When entering and leaving the parking area, the barrier is opened with an AP open command (terminal block).

Once the vehicle has crossed the barrier and released contact FT (NC) (e.g. from magnetic loop), the barrier closes immediately. When parameter 21 = 00, the barrier opens and remains open until the vehicle has completed the passage. If the vehicle moves back, the barrier remains open.

NOTE: it is possible to add further 5 s delay before closing, setting A 5 99.

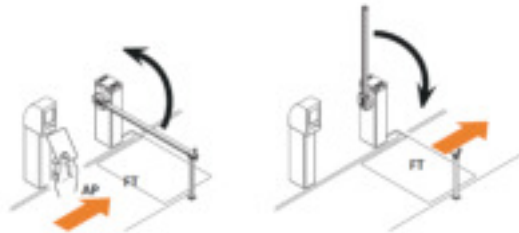

Directional mode 1 (83 02)

When entering the parking area, the barrier is opened with an AP open command (terminal block).

Once the vehicle has crossed the barrier and released contacts FT (NC) and PED (NO), the barrier closes. When leaving the parking area, the barrier is opened by a PED command received from the magnetic loop.

Once the vehicle has crossed the barrier and released contact FT (NC), the barrier closes.

When parameter 21 = 00, the barrier opens and remains open until the vehicle has completed the passage. If the vehicle moves back, the barrier remains open.

NOTE: it is possible to add further 5 s delay before closing, setting A 5 99.

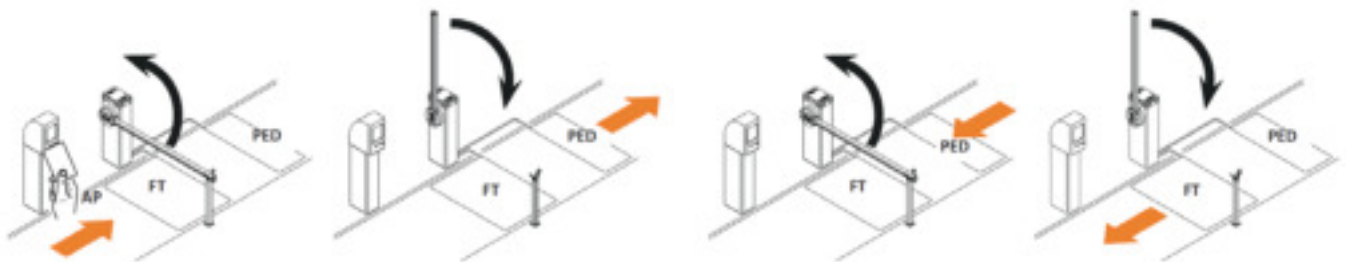

Directional mode 2 (83 03)

When entering, the barrier is opened with an AP open command (terminal block), and closes after the automatic closing time set with parameter 21.

NOTE: in order to have the automatic closing, it is recommended to set parameter 21 different to 00.

When leaving the parking area, the barrier is opened by a PED (NO) command received from the magnetic loop. Once the vehicle has crossed the barrier and released contact FT (NC), the barrier closes.

